

10-MHz To 66-MHz, 10:1 LVDS SERIALIZER/DESERIALIZER

FEATURES

- **Controlled Baseline**
 - One Assembly/Test Site, One Fabrication Site
 - **Extended Temperature Performance of –55°C to 125°C**
 - **Enhanced Diminishing Manufacturing Sources (DMS) Support**
 - **Enhanced Product-Change Notification**
 - **Qualification Pedigree ⁽¹⁾**
- (1) Component qualification in accordance with JEDEC and industry standards to ensure reliable operation over an extended temperature range. This includes, but is not limited to, Highly Accelerated Stress Test (HAST) or biased 85/85, temperature cycle, autoclave or unbiased HAST, electromigration, bond intermetallic life, and mold compound life. Such qualification testing should not be viewed as justifying use of this component beyond specified performance and environmental limits.
- **100-Mbps to 660-Mbps Serial LVDS Data Payload Bandwidth at 10-MHz to 66-MHz System Clock**
 - **Pin-Compatible Superset of DS92LV1023/DS92LV1224**
 - **Chipset (Serializer/Deserializer) Power Consumption <450 mW (Typ) at 66 MHz**
 - **Synchronization Mode for Faster Lock**
 - **Lock Indicator**
 - **No External Components Required for PLL**
 - **28-Pin SSOP and Space Saving 5 × 5 mm QFN Packages Available**
 - **Programmable Edge Trigger on Clock**
 - **Flow-Through Pinout for Easy PCB Layout**

DESCRIPTION

The SN65LV1023A serializer and SN65LV1224B deserializer comprise a 10-bit serdes chipset designed to transmit and receive serial data over LVDS differential backplanes at equivalent parallel word rates from 10 MHz to 66 MHz. Including overhead, this translates into a serial data rate between 120-Mbps and 792-Mbps payload encoded throughput.

Upon power up, the chipset link can be initialized via a synchronization mode with internally generated SYNC patterns or the deserializer can be allowed to synchronize to random data. By using the synchronization mode, the deserializer establishes lock within specified, shorter time parameters.

The device can be entered into a power-down state when no data transfer is required. Alternatively, a mode is available to place the output pins in the high-impedance state without losing PLL lock.

The SN65LV1023A and SN65LV1224B are characterized for operation over ambient air temperature of –55°C to 125°C.

ORDERING INFORMATION

T _A	PACKAGE ⁽¹⁾		ORDERABLE PART NUMBER	TOP-SIDE MARKING
-55°C to 125°C	SSOP - DB	Reel of 2000	SN65LV1023AMDBREP	LV1023AMEP
-55°C to 125°C	SSOP - DB	Reel of 2000	SN65LV1224BMDREP	LV1224BMEP

- (1) Package drawings, standard packing quantities, thermal data, symbolization, and PCB design guidelines are available at www.ti.com/sc/package.



Please be aware that an important notice concerning availability, standard warranty, and use in critical applications of Texas Instruments semiconductor products and disclaimers thereto appears at the end of this data sheet.

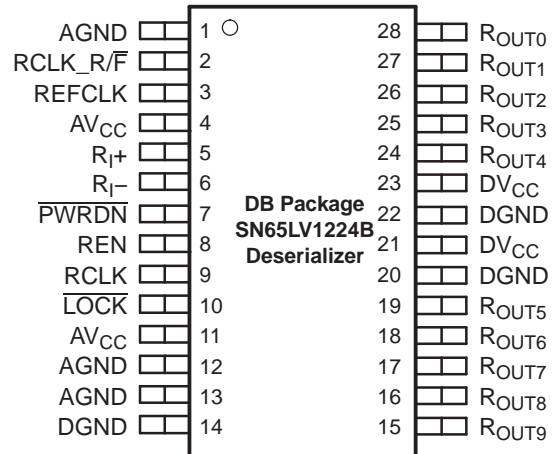
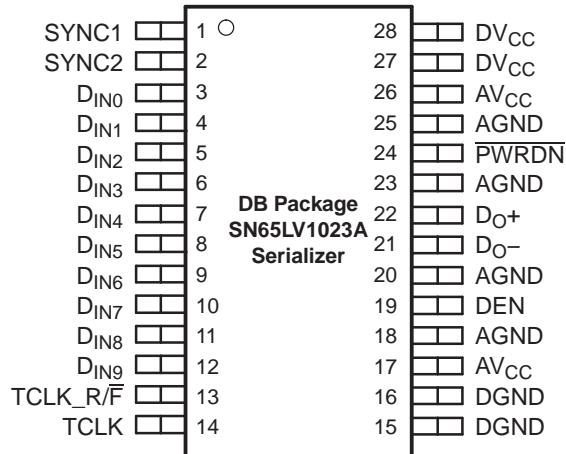

BLOCK DIAGRAMS

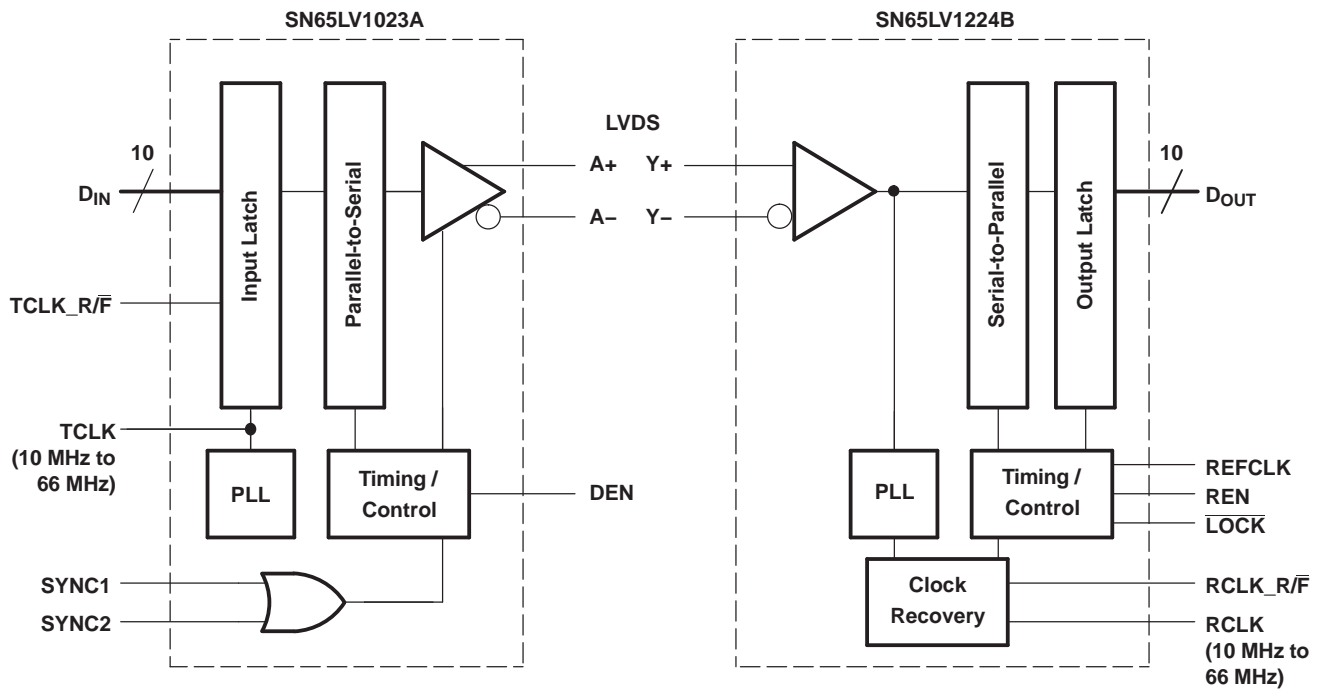

FUNCTIONAL DESCRIPTION

The SN65LV1023A and SN65LV1224B are a 10-bit serializer/deserializer chipset designed to transmit data over differential backplanes or unshielded twisted pair (UTP) at clock speeds from 10 MHz to 66 MHz. The chipset has five states of operation: initialization mode, synchronization mode, data transmission mode, power-down mode, and high-impedance mode. The following sections describe each state of operation.

SYNCHRONIZATION-PATTERN GENERATION (SN65LV1023A)

The synchronization-pattern generation is designed to work, as follows:

After SYNC1 or SYNC2 is held high for at least 6T (T = 1 refclk cycle), the SYNC pattern is generated on the serial line for 1026T. During this 1026-cycle SYNC pattern transmission, it is not required that SYNC1 or SYNC2 be held high.

There are two different cases in which this SYNC pattern generation might be used:

1. SYNC1 or SYNC2 is held high once at least 6T, but no more than 1026T:

In this case, the sync-pattern generation should generate 1026T of SYNC pattern only once, and the data that follows the SYNC pattern on the serial line should reflect the parallel inputs. In this scenario, the sync pattern generation is working as it is designed.

2. SYNC1 or SYNC2 is held high continuously at least 1038T (6T to invoke the first series of SYNC pattern, and 1026T, which is the duration of the first series of the SYNC pattern, and 6T to invoke the second series of the SYNC pattern):

If the sync-pattern generator operates as it is intended, the user should be able to observe the continuous SYNC pattern on the serial line. For example, if the SYNC1 or SYNC2 is held high for 1039T, a user can see the SYNC pattern being generated continuously for 2052T (=1026T+1026T). However, as shown in [Figure 1](#), the device behaves in a way that, if the SYNC1 or SYNC2 is held high for more than 1038T, it sends out 1028T of SYNC pattern, plus 4T of data (which reflects the data that is present on the parallel input at that time) and another 1026T of SYNC pattern. [Figure 1](#) basically shows how the data on the serial line would be affected if the SYNC1 or SYNC2 is held for an extended period of time.

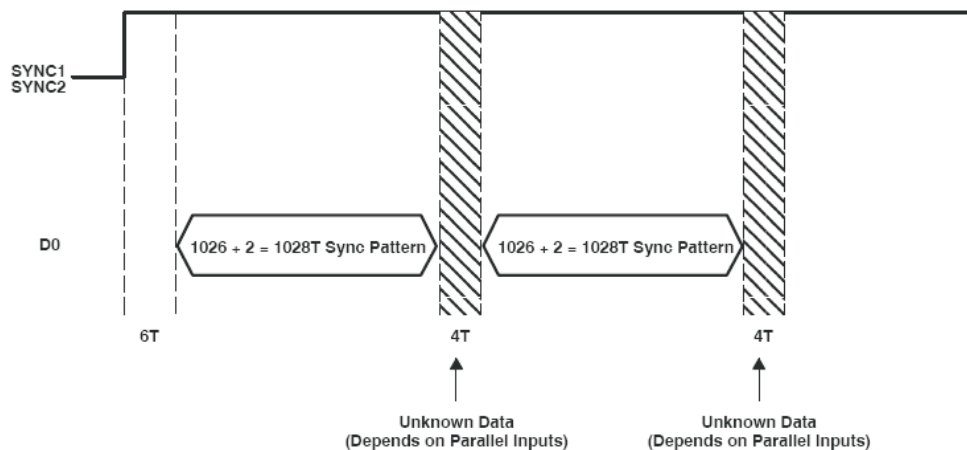

Figure 1. Sync-Pattern Generation

FUNCTIONAL DESCRIPTION (continued)

INITIALIZATION MODE

Initialization of both devices must occur before data transmission can commence. Initialization refers to synchronization of the serializer and deserializer PLLs to local clocks.

When V_{CC} is applied to the serializer and/or deserializer, the respective outputs enter the high-impedance state, while on-chip power-on circuitry disables internal circuitry. When V_{CC} reaches 2.45 V, the PLL in each device begins locking to a local clock. For the serializer, the local clock is the transmit clock (TCLK) provided by an external source. For the deserializer, a local clock must be applied to the REFCLK pin. The serializer outputs remain in the high-impedance state, while the PLL locks to the TCLK.

SYNCHRONIZATION MODE

The deserializer PLL must synchronize to the serializer in order to receive valid data. Synchronization can be accomplished in one of two ways:

- **Rapid Synchronization:** The serializer has the capability to send specific SYNC patterns consisting of six ones and six zeros switching at the input clock rate. The transmission of SYNC patterns enables the deserializer to lock to the serializer signal within a deterministic time frame. This transmission of SYNC patterns is selected via the SYNC1 and SYNC2 inputs on the serializer. Upon receiving valid SYNC1 or SYNC2 pulse (wider than 6 clock cycles), 1026 cycles of SYNC pattern are sent.

When the deserializer detects *edge* transitions at the LVDS input, it attempts to lock to the embedded clock information. The deserializer \overline{LOCK} output remains high while its PLL locks to the incoming data or SYNC patterns present on the serial input. When the deserializer locks to the LVDS data, the \overline{LOCK} output goes low. When \overline{LOCK} is low, the deserializer outputs represent incoming LVDS data. One approach is to tie the deserializer \overline{LOCK} output directly to SYNC1 or SYNC2.

- **Random-Lock Synchronization:** The deserializer can attain lock to a data stream without requiring the serializer to send special SYNC patterns. This allows the SN65LV1224B to operate in open-loop applications. Equally important is the deserializer's ability to support hot insertion into a running backplane. In the open-loop or hot-insertion case, it is assumed the data stream is essentially random. Therefore, because lock time varies due to data stream characteristics, the exact lock time cannot be predicted. The primary constraint on the random lock time is the initial phase relation between the incoming data and the REFCLK when the deserializer powers up.

The data contained in the data stream can also affect lock time. If a specific pattern is repetitive, the deserializer could enter false lock—falsely recognizing the data pattern as the start/stop bits. This is referred to as repetitive multitransition (RMT); see [Figure 2](#) for RMT examples. This occurs when more than one low-high transition takes place per clock cycle over multiple cycles. In the worst case, the deserializer could become locked to the data pattern rather than the clock. Circuitry within the deserializer can detect that the possibility of false lock exists. Upon detection, the circuitry prevents the \overline{LOCK} output from becoming active until the potential false lock pattern changes. Notice that the RMT pattern only affects the deserializer lock time, and once the deserializer is in lock, the RMT pattern does not affect the deserializer state as long as the same data boundary happens each cycle. The deserializer does not go into lock until it finds a unique four consecutive cycles of data boundary (stop/start bits) at the same position.

The deserializer stays in lock until it cannot detect the same data boundary (stop/start bits) for four consecutive cycles. Then the deserializer goes out of lock and hunts for the new data boundary (stop/start bits). In the event of loss of synchronization, the \overline{LOCK} pin output goes high and the outputs (including RCLK) enter a high-impedance state. The user's system should monitor the \overline{LOCK} pin in order to detect a loss of synchronization. Upon detection of loss of lock, sending sync patterns for resynchronization is desirable if reestablishing lock within a specific time is critical. However, the deserializer can lock to random data as previously noted.

FUNCTIONAL DESCRIPTION (continued)

D_{IN0} Held Low and D_{IN1} Held High

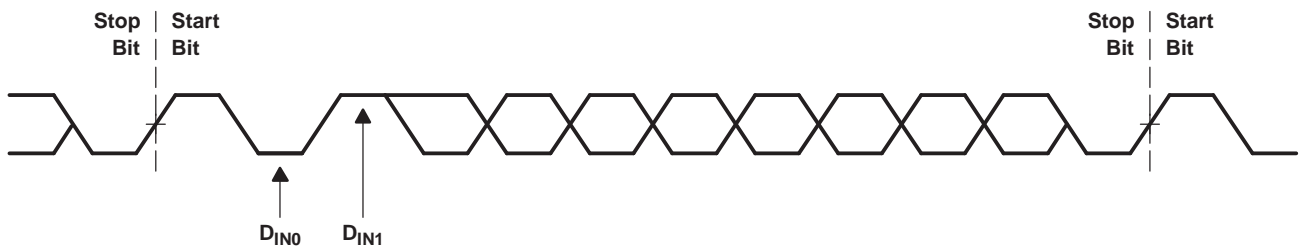

D_{IN4} Held Low and D_{IN5} Held High

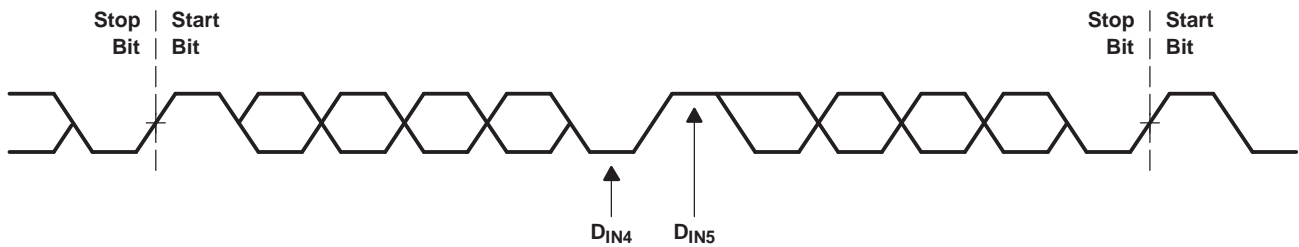

D_{IN8} Held Low and D_{IN9} Held High

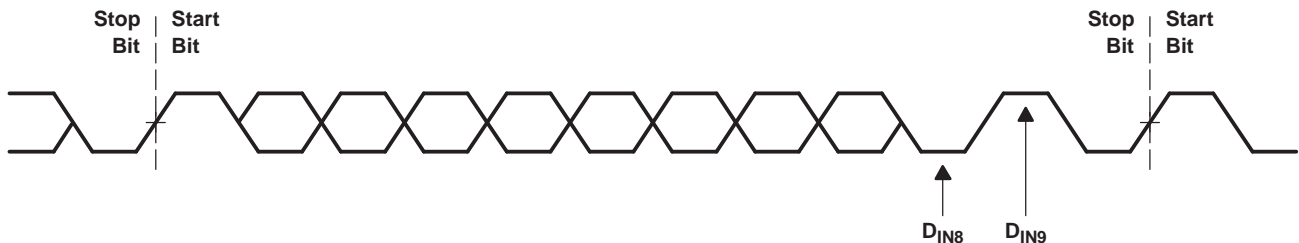

Figure 2. RMT Pattern Examples

DATA TRANSMISSION MODE

After initialization and synchronization, the serializer accepts parallel data from inputs D_{IN0} – D_{IN9} . The serializer uses the $TCLK$ input to latch the incoming data. The $TCLK_R/\bar{F}$ pin selects which edge the serializer uses to strobe incoming data. If either of the $SYNC$ inputs is high for six $TCLK$ cycles, the data at D_{IN0} – D_{IN9} is ignored regardless of the clock edge selected and 1026 cycles of $SYNC$ pattern are sent.

After determining which clock edge to use, a start and stop bit, appended internally, frames the data bits in the register. The start bit is always high and the stop bit is always low. The start and stop bits function as the embedded clock bits in the serial stream.

The serializer transmits serialized data and appended clock bits (10+2 bits) from the serial data output (DO_{\pm}) at 12 times the $TCLK$ frequency. For example, if $TCLK$ is 66 MHz, the serial rate is $66 \times 12 = 792$ Mbps. Because only 10 bits are input data, the useful data rate is 10 times the $TCLK$ frequency. For instance, if $TCLK = 66$ MHz, the useful data rate is $66 \times 10 = 660$ Mbps. The data source, which provides $TCLK$, must be in the range of 10 MHz to 66 MHz.

The serializer outputs (DO_{\pm}) can drive point-to-point connections or limited multipoint or multidrop backplanes. The outputs transmit data when the enable pin (DEN) is high, $\overline{PWRDN} = \text{high}$, and $SYNC1$ and $SYNC2$ are low. When DEN is driven low, the serializer output pins enter the high-impedance state.

FUNCTIONAL DESCRIPTION (continued)

Once the deserializer has synchronized to the serializer, the $\overline{\text{LOCK}}$ pin transitions low. The deserializer locks to the embedded clock and uses it to recover the serialized data. ROUT data is valid when $\overline{\text{LOCK}}$ is low, otherwise $\text{R}_{\text{OUT}0}\text{--}\text{R}_{\text{OUT}9}$ is invalid. The $\text{R}_{\text{OUT}0}\text{--}\text{R}_{\text{OUT}9}$ data is strobed out by RCLK. The specific RCLK edge polarity to be used is selected by the RCLK_R/F input. The $\text{R}_{\text{OUT}0}\text{--}\text{R}_{\text{OUT}9}$, $\overline{\text{LOCK}}$ and RCLK outputs can drive a maximum of three CMOS input gates (15-pF load total for all three) with a 66-MHz clock.

POWER DOWN

When no data transfer is required, the power-down mode can be used. The serializer and deserializer use the power-down state, a low-power sleep mode, to reduce power consumption. The deserializer enters power down when you drive $\overline{\text{PWRDN}}$ and REN low. The serializer enters power down when you drive $\overline{\text{PWRDN}}$ low. In power down, the PLL stops and the outputs enter a high-impedance state, which disables load current and reduces supply current to the milliampere range. To exit power down, you must drive the $\overline{\text{PWRDN}}$ pin high.

Before valid data exchanges between the serializer and deserializer can resume, you must reinitialize and resynchronize the devices to each other. Initialization of the serializer takes 1026 TCLK cycles. The deserializer initialize and drives $\overline{\text{LOCK}}$ high until lock to the LVDS clock occurs.

HIGH-IMPEDANCE MODE

The serializer enters the high-impedance mode when the DEN pin is driven low. This puts both driver output pins (DO+ and DO–) into a high-impedance state. When you drive DEN high, the serializer returns to the previous state, as long as all other control pins remain static (SYNC1, SYNC2, $\overline{\text{PWRDN}}$, TCLK_R/F). When the REN pin is driven low, the deserializer enters high-impedance mode. Consequently, the receiver output pins ($\text{R}_{\text{OUT}0}\text{--}\text{R}_{\text{OUT}9}$) and RCLK are placed into the high-impedance state. The $\overline{\text{LOCK}}$ output remains active, reflecting the state of the PLL.

Deserializer Truth Table

INPUTS		OUTPUTS		
PWRDN	REN	ROUT(0:9) ⁽¹⁾	LOCK ⁽²⁾	RCLK ⁽¹⁾⁽³⁾
H	H	Z	H	Z
H	H	Active	L	Active
L	X	Z	Z	Z
H	L	Z	Active	Z

(1) ROUT and RCLK are 3-stated when $\overline{\text{LOCK}}$ is asserted high.

(2) $\overline{\text{LOCK}}$ output reflects the state of the deserializer with regard to the selected data stream.

(3) RCLK active indicates the RCLK is running if the deserializer is locked. The timing of RCLK with respect to ROUT is determined by RCLK_R/F.

FAILSAFE BIASING FOR THE SN65LV1224B

The SN65LV1224B has an input threshold sensitivity of ± 50 mV. This allows for greater differential noise margin in the SN65LV1224B. However, in cases where the receiver input is not being actively driven, the increased sensitivity of the SN65LV1224B can pickup noise as a signal and cause unintentional locking. This may occur when the input cable is disconnected. The SN65LV1224B has an on-chip fail-safe circuit that drives the serial input and $\overline{\text{LOCK}}$ signal high. The response time of the fail-safe circuit depends on interconnect characteristics.

TERMINAL FUNCTIONS

PIN DB PACKAGE	I/O	DESCRIPTION
SERIALIZER		
18, 20, 23, 25	AGND	Analog circuit ground (PLL and analog circuits)
17, 26	AV _{CC}	Analog circuit power supply (PLL and analog circuits)
19	DEN	LVTTL logic input. Low puts the LVDS serial output into the high-impedance state. High enables serial data output.
15, 16	DGND	Digital circuit ground
3–12	D _{IN0} – D _{IN9}	Parallel LVTTL data inputs
21	D _{O–}	Inverting LVDS differential output
22	D _{O+}	Noninverting LVDS differential output
27, 28	DV _{CC}	Digital circuit power supply
24	$\overline{\text{PWRDN}}$	LVTTL logic input. Asserting this pin low turns off the PLL and places the outputs into the high-impedance state, putting the device into a low-power mode.
1, 2	SYNC1, SYNC2	LVTTL logic inputs SYNC1 and SYNC2 are ORed together. When at least one of the two pins is asserted high for 6 cycles of TCLK, the serializer initiates transmission of a minimum 1026 SYNC patterns. If after completion of the transmission of 1026 patterns SYNC continues to be asserted, then the transmission continues until SYNC is driven low and if the time SYNC holds > 6 cycles, another 1026 SYNC pattern transmission initiates.
13	TCLK_R/F	LVTTL logic input. Low selects a TCLK falling-edge data strobe; high selects a TCLK rising-edge data strobe.
14	TCLK	LVTTL-level reference clock input. The SN65LV1023A accepts a 10-MHz to 66-MHz clock. TCLK strobes parallel data into the input latch and provides a reference frequency to the PLL.
DESERIALIZER		
1, 12, 13	AGND	Analog circuit ground (PLL and analog circuits)
4, 11	AV _{CC}	Analog circuit power supply (PLL and analog circuits)
14, 20, 22	DGND	Digital circuit ground
21, 23	DV _{CC}	Digital circuit power supply
10	$\overline{\text{LOCK}}$	LVTTL level output. $\overline{\text{LOCK}}$ goes low when the deserializer PLL locks onto the embedded clock edge.
7	$\overline{\text{PWRDN}}$	LVTTL logic input. Asserting this pin low turns off the PLL and places outputs into a high-impedance state, putting the device into a low-power mode. To initiate power down, this pin is held low for a minimum of 16 ns. As long as $\overline{\text{PWRDN}}$ is held low, the device is in the power down state.
2	RCLK_R/F	LVTTL logic input. Low selects an RCLK falling-edge data strobe; high selects an RCLK rising-edge data strobe.
9	RCLK	LVTTL level output recovered clock. Use RCLK to strobe ROUTH.
3	REFCLK	LVTTL logic input. Use this pin to supply a REFCLK signal for the internal PLL frequency.
8	REN	LVTTL logic input. Low places R _{OUT0} –R _{OUT9} and RCLK in the high-impedance state.
5	R _{I+}	Serial data input. Noninverting LVDS differential input
6	R _{I–}	Serial data input. Inverting LVDS differential input
28–24, 19–15	R _{OUT0} –R _{OUT9}	Parallel LVTTL data outputs

ABSOLUTE MAXIMUM RATINGS

over operating free-air temperature range (unless otherwise noted)⁽¹⁾

		UNIT
V _{CC} to GND		–0.3 V to 4 V
LVTTTL input voltage		–0.3 V to (V _{CC} + 0.3 V)
LVTTTL output voltage		–0.3 V to (V _{CC} + 0.3 V)
LVDS receiver input voltage		–0.3 V to 3.9 V
LVDS driver output voltage		–0.3 V to 3.9 V
LVDS output short circuit duration		10 ms
Electrostatic discharge:	HBM	up to 6 kV
	MM	up to 200 V
Junction temperature		150°C
Storage temperature ⁽²⁾		–65°C to 150°C
Lead temperature (soldering, 4 seconds)		260°C
DB package maximum package power dissipation	T _A = 25°C	1.27 W
DB package derating		10.8 mW/°C above 25°C

- (1) Stresses beyond those listed under absolute maximum ratings may cause permanent damage to the device. These are stress ratings only, and functional operation of the device at these or any other conditions beyond those indicated under recommended operating conditions is not implied. Exposure to absolute-maximum-rated conditions for extended periods may affect device reliability.
- (2) Long term high temperature storage and/or extended use at maximum operating conditions may result in a reduction of overall device life. See http://www.ti.com/ep_quality for additional information on enhanced plastic packaging.

RECOMMENDED OPERATING CONDITIONS

over operating free-air temperature range (unless otherwise noted)

		MIN	NOM	MAX	UNIT
V _{CC} ⁽¹⁾	Supply voltage	3	3.3	3.6	V
	Receiver input voltage range	0		2.4	V
V _{CM}	Receiver input common mode range	$\frac{V_{ID}}{2}$	$2.4 - \left(\frac{V_{ID}}{2}\right)$		V
	Supply noise voltage			100	mVp-p
T _A	Operating free-air temperature	–55	25	125	°C

- (1) By design, DVCC and AVCC are separated internally and does not matter what the difference is for |DVCC–AVCC|, as long as both are within 3 V to 3.6 V.

ELECTRICAL CHARACTERISTICS

over recommended operating supply and temperature ranges (unless otherwise specified)

PARAMETER		TEST CONDITIONS	MIN	TYP	MAX	UNIT
SERIALIZER LVCMOS/LVTTL DC SPECIFICATIONS⁽¹⁾						
V _{IH}	High-level input voltage		2		V _{CC}	V
V _{IL}	Low-level input voltage		GND		0.8	V
V _{CL}	Input clamp voltage	I _{CL} = -18 mA		-0.86	-1.5	V
I _{IN}	Input current, ⁽²⁾	V _{IN} = 0 V or 3.6 V	-200	±100	200	μA
DESERIALIZER LVCMOS/LVTTL DC SPECIFICATIONS⁽³⁾						
V _{IH}	High-level input voltage		2		V _{CC}	V
V _{IL}	Low-level input voltage		GND		0.8	V
V _{CL}	Input clamp voltage	I _{CL} = -18 mA		-0.62	-1.5	V
I _{IN}	Input current (pull-up and pull-down resistors on inputs)	V _{IN} = 0 V or 3.6 V	-200		200	μA
V _{OH}	High-level output voltage	I _{OH} = -5 mA	2.2	3	V _{CC}	V
V _{OL}	Low-level output voltage	I _{OL} = 5 mA	GND	0.25	0.5	V
I _{OS}	Output short-circuit current	V _{OUT} = 0 V		-47	-85	mA
I _{OZ}	High-impedance output current	$\overline{\text{PWRDN}}$ or REN = 0.8 V, V _{OUT} = 0 V or V _{CC}	-10	±1	10	μA
SERIALIZER LVDS DC SPECIFICATIONS (Apply to Pins DO+ and DO-)						
V _{OD}	Output differential voltage (DO+)-(DO-)	R _L = 27 Ω, See Figure 20	350	450		mV
ΔV _{OD}	Output differential voltage unbalance				35	mV
V _{OS}	Offset voltage		1.1	1.2	1.3	V
ΔV _{OS}	Offset voltage unbalance			4.8	35	mV
I _{OS}	Output short circuit current	DO = 0 V, D _{INx} = high, $\overline{\text{PWRDN}}$ and DEN = 2.4 V		-10	-90	mA
I _{OZ}	High-impedance output current	$\overline{\text{PWRDN}}$ or DEN = 0.8 V, DO = 0 V or V _{CC}	-10	±1	10	μA
I _{OX}	Power-off output current	V _{CC} = 0 V, DO = 0 V or 3.6 V	-20	±1	25	μA
C _O	Output single-ended capacitance			1		pF
DESERIALIZER LVDS DC SPECIFICATIONS (Apply to Pins RI+ and RI-)						
V _{TH}	Differential threshold high voltage	V _{CM} = 1.1 V			50	mV
V _{TL}	Differential threshold low voltage		-50			mV
I _{IN}	Input current	V _{IN} = 2.4 V, V _{CC} = 3.6 V or 0 V	-10	±1	15	μA
		V _{IN} = 0 V, V _{CC} = 3.6 V or 0 V	-10	±0.05	10	μA
C _I	Input single-ended capacitance			0.5		pF
SERIALIZER SUPPLY CURRENT (Applies to Pins DVCC and AVCC)						
I _{CCD}	Serializer supply current worst case	R _L = 27 Ω, See Figure 5	f = 10 MHz	20	25	mA
			f = 66 MHz	55	70	
I _{CCXD}	Serializer supply current	$\overline{\text{PWRDN}}$ = 0.8 V		200	500	μA
DESERIALIZER SUPPLY CURRENT (applies to pins DVCC and AVCC)						
I _{CCR}	Deserializer supply current, worst case	C _L = 15 pF, See Figure 5	f = 10 MHz	15	35	mA
			f = 66 MHz	80	95	
I _{CCXR}	Deserializer supply current, power down	$\overline{\text{PWRDN}}$ = 0.8 V, REN = 0.8 V		0.36	1	mA

(1) Apply to D_{IN0}-D_{IN9}, TCLK, $\overline{\text{PWRDN}}$, TCLK_R/F, SYNC1, SYNC2, and DEN

(2) High I_{IN} values are due to pullup and pulldown resistors on the inputs.

(3) Apply to pins $\overline{\text{PWRDN}}$, RCLK_R/F, REN, and REFCLK = inputs; apply to pins R_{OUTx}, RCLK, and $\overline{\text{LOCK}}$ = outputs (see Deserializer truth table)

SERIALIZER TIMING REQUIREMENTS FOR TCLK

over recommended operating supply and temperature ranges (unless otherwise specified)

PARAMETER	TEST CONDITIONS	MIN	TYP	MAX	UNIT
t_{TCP}	Transmit clock period	15.15	T	100	ns
t_{TCH}	Transmit clock high time	0.4T	0.5T	0.6T	ns
t_{TCL}	Transmit clock low time	0.4T	0.5T	0.6T	ns
$t_{i(CLK)}$	TCLK input transition time		3	6	ns
t_{JIT}	TCLK input jitter	See Figure 19		150	ps (RMS)
	Frequency tolerance	-100		+100	ppm

SERIALIZER SWITCHING CHARACTERISTICS

over recommended operating supply and temperature ranges (unless otherwise specified)

PARAMETER	TEST CONDITIONS	MIN	TYP	MAX	UNIT	
$t_{TLH(L)}$	LVDS low-to-high transition time	$R_L = 27 \Omega$, $C_L = 10$ pF to GND, See Figure 6	0.2		ns	
$t_{LTH(L)}$	LVDS high-to-low transition time		0.25		ns	
$t_{su(DI)}$	DIN0–DIN9 setup to TCLK	$R_L = 27 \Omega$, $C_L = 10$ pF to GND, See Figure 9	0.5		ns	
$t_{su(DI)}$	DIN0–DIN9 hold from TCLK		4		ns	
$t_{d(HZ)}$	DO± high-to-high impedance state delay	$R_L = 27 \Omega$, $C_L = 10$ pF to GND, See Figure 10	2.5		ns	
$t_{d(LZ)}$	DO± low-to-high impedance state delay		2.5			
$t_{d(ZH)}$	DO± high-to-high impedance state-to-high delay		5			
$t_{d(ZL)}$	DO± high-to-high impedance state-to-low delay		6.5			
$t_{w(SPW)}$	SYNC pulse duration	$R_L = 27 \Omega$, See Figure 12	$6 \times t_{TCP}$		ns	
$t_{(PLD)}$	Serializer PLL lock time		$1026 \times t_{TCP}$		ns	
$t_{d(S)}$	Serializer delay	$R_L = 27 \Omega$, See Figure 13	t_{TCP}	$t_{TCP}+2$	$t_{TCP}+3$	ns
t_{DJIT}	Deterministic jitter	$R_L = 27 \Omega$, $C_L = 10$ pF to GND	230		ps	
			150			
t_{RJIT}	Random jitter	$R_L = 2.7 \Omega$, $C_L = 10$ pF to GND	10		ps (RMS)	

DESERIALIZER TIMING REQUIREMENTS FOR REFCLK

over recommended operating supply and temperature ranges (unless otherwise specified)

PARAMETER	TEST CONDITIONS	MIN	TYP	MAX	UNIT
t_{RFCP}	REFCLK period	15.15	T	100	ns
t_{RFDC}	REFCLK duty cycle	30%	50%	70%	
$t_{i(RF)}$	REFCLK transition time		3	6	ns
	Frequency tolerance	-100		+100	ppm

DESERIALIZER SWITCHING CHARACTERISTICS

over recommended operating supply and temperature ranges (unless otherwise specified)

PARAMETER		TEST CONDITIONS	PIN/FREQ	MIN	TYP	MAX	UNIT
$t_{(RCP)}$	Receiver out clock period	$t_{(RCP)} = t_{(TCP)}$, See Figure 13	RCLK	15.15		100	ns
$t_{TLH(C)}$	CMOS/TTL low-to-high transition time	$C_L = 15$ pF, $CL = 15$ pF, See Figure 7	ROUT0–ROUT9		1.2		ns
$t_{THL(C)}$	CMOS/TTL high-to-low transition time		\overline{LOCK} , RCLK		1.1		
$t_{d(D)}^{(1)}$	Deserializer delay, See Figure 14	Room temperature, 3.3 V	10 MHz	$1.75 \times t_{(RCP)}$ +4.2		$1.75 \times t_{(RCP)}$ +12.6	ns
			66 MHz	$1.75 \times t_{(RCP)}$ +7.4		$1.75 \times t_{(RCP)}$ +9.7	ns
$t_{(ROS)}$	R_{OUTx} data valid before RCLK	See Figure 15	RCLK 10 MHz	$0.4 \times t_{(RCP)}$	$0.5 \times t_{(RCP)}$		ns
			RCLK 66 MHz	$0.4 \times t_{(RCP)}$	$0.5 \times t_{(RCP)}$		
$t_{(ROH)}$	R_{OUTx} data valid after RCLK		10 MHz	$-0.4 \times t_{(RCP)}$	$-0.5 \times t_{(RCP)}$		
			66 MHz	$-0.4 \times t_{(RCP)}$	$-0.5 \times t_{(RCP)}$		
$t_{(RDC)}$	RCLK duty cycle			40%	50%	60%	ns
$t_{d(HZ)}$	High-to-high impedance state delay	See Figure 16	R_{OUT0} – R_{OUT9}		6.5		ns
$t_{d(LZ)}$	Low-to-high impedance state delay				4.7		ns
$t_{d(HR)}$	High-impedance state to high delay				5.3		ns
$t_{d(ZL)}$	High-impedance state to low delay				4.7		ns
$t_{(DSR1)}$	Deserializer PLL lock time from PWRDN (with SYNCPAT)	See Figure 17, Figure 18, and (2)	10 MHz			$850 \times t_{RFCP}$	μ s
			66 MHz			$850 \times t_{RFCP}$	
$t_{(DSR2)}$	Deserializer PLL lock time from SYNCPAT		10 MHz			2	ns
			66 MHz			0.303	
$t_{d(ZHLK)}$	High-impedance state to high delay (power up)			\overline{LOCK}		3	ns
t_{RNM}	Deserializer noise margin		See Figure 19 and (3)	10 MHz		3680	
		66 MHz			540		

(1) The deserializer delay time for all frequencies does not exceed two serial bit times.

(2) $t_{(DSR1)}$ represents the time required for the deserializer to register that a lock has occurred upon powerup or when leaving the powerdown mode. $t_{(DSR2)}$ represents the time required to register that a lock has occurred for the powered up and enabled deserializer when the input (RI±) conditions change from not receiving data to receiving synchronization patterns (SYNCPATs). In order to specify deserializer PLL performance, $t_{(DSR1)}$ and $t_{(DSR2)}$ are specified with REFCLK active and stable and specific conditions of SYNCPATs.

(3) t_{RNM} represents the phase noise or jitter that the deserializer can withstand in the incoming data stream before bit errors occur.

TIMING DIAGRAMS AND TEST CIRCUITS

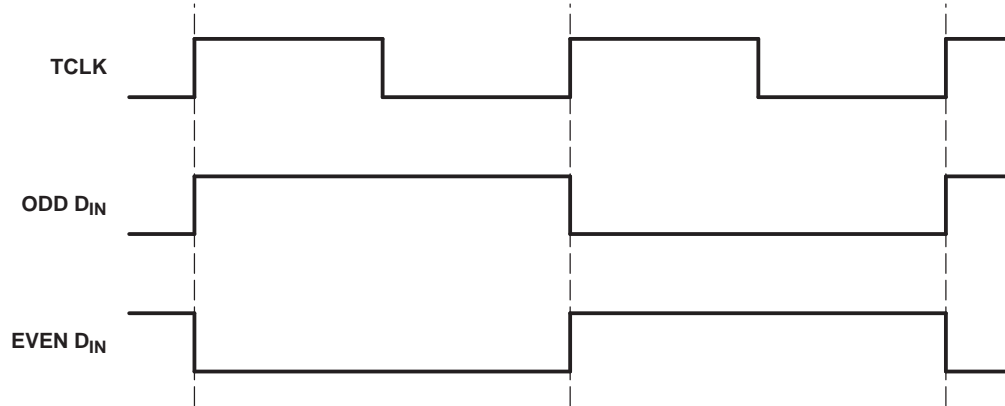

Figure 3. Worst-Case Serializer I_{CC} Test Pattern

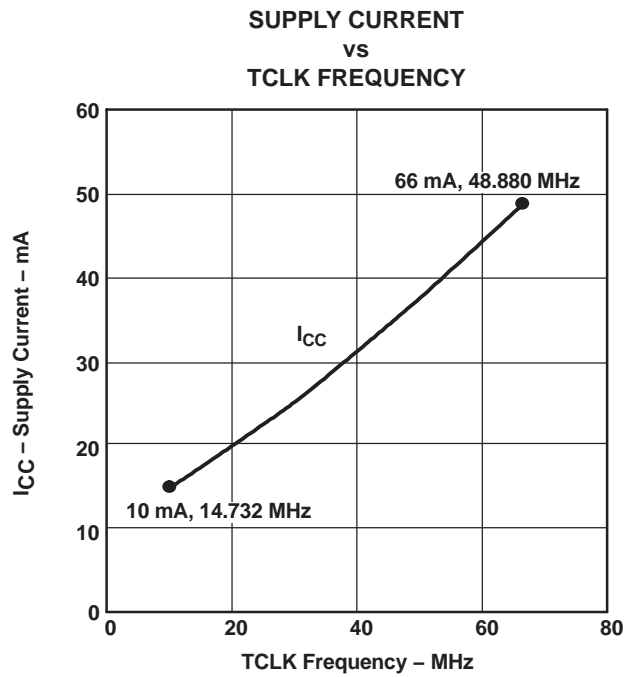

Figure 4.

TIMING DIAGRAMS AND TEST CIRCUITS (continued)

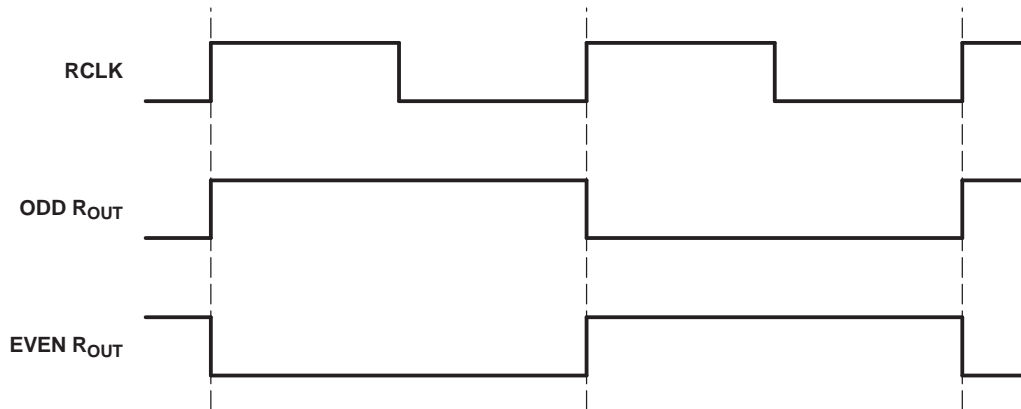

Figure 5. Worst-Case Deserializer I_{CC} Test Pattern

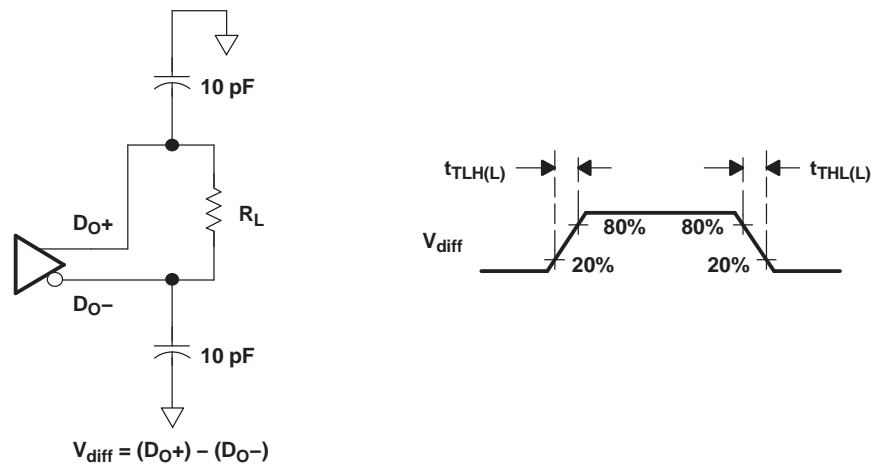

Figure 6. Serializer LVDS Output Load and Transition Times

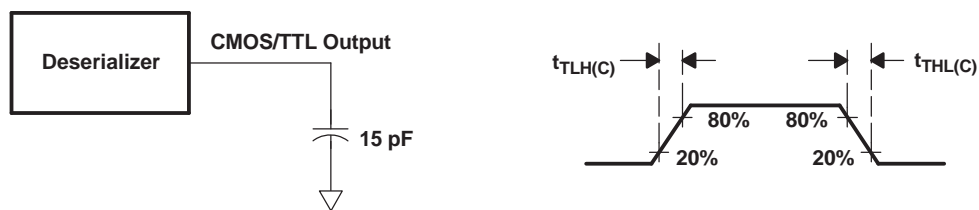

Figure 7. Deserializer CMOS/TTL Output Load and Transition Times

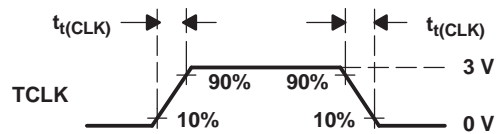

Figure 8. Serializer Input Clock Transition Time

TIMING DIAGRAMS AND TEST CIRCUITS (continued)

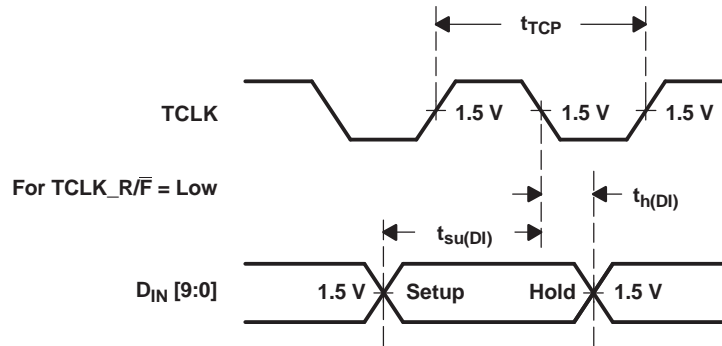

Figure 9. Serializer Setup/Hold Times

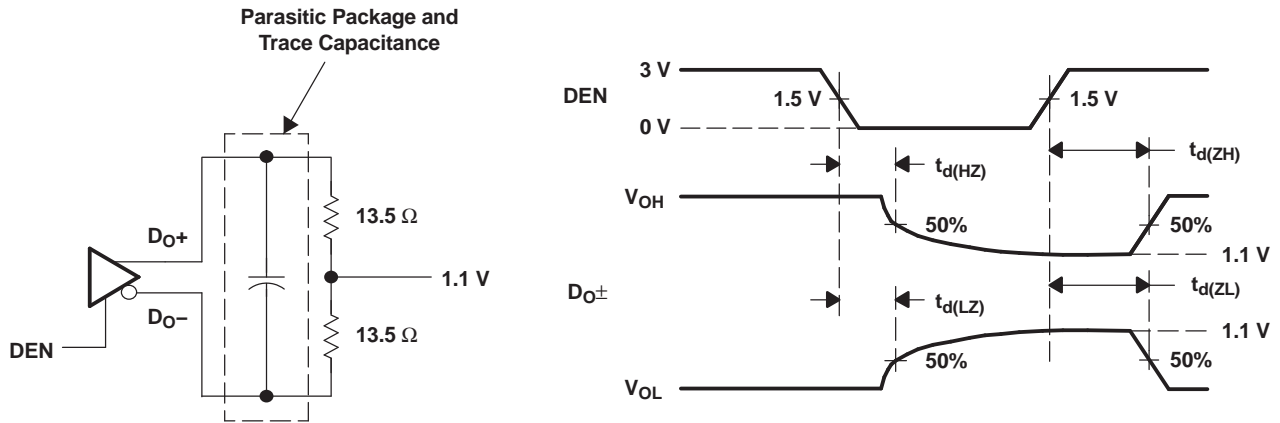

Figure 10. Serializer High-Impedance State Test Circuit and Timing

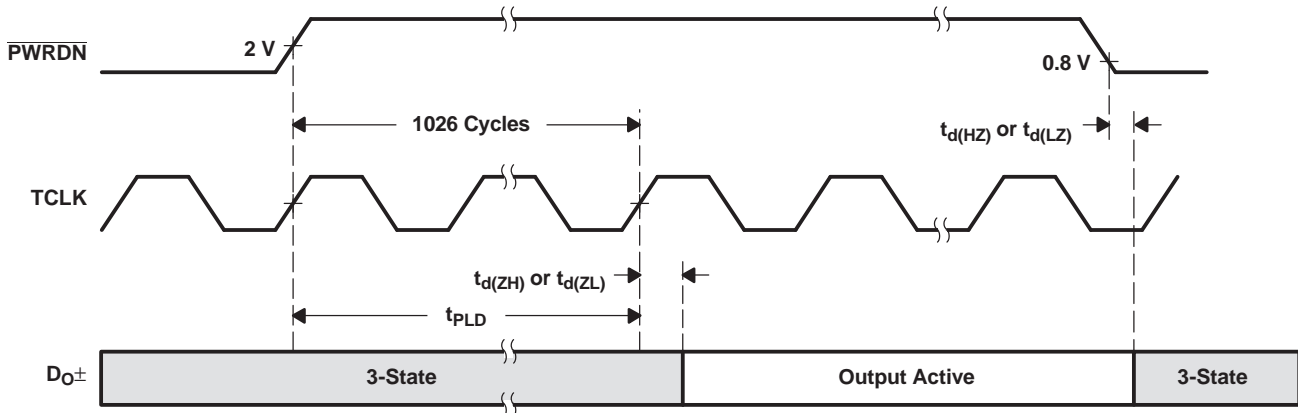

Figure 11. Serializer PLL Lock Time and $\overline{\text{PWRDN}}$ High-Impedance State Delays

TIMING DIAGRAMS AND TEST CIRCUITS (continued)

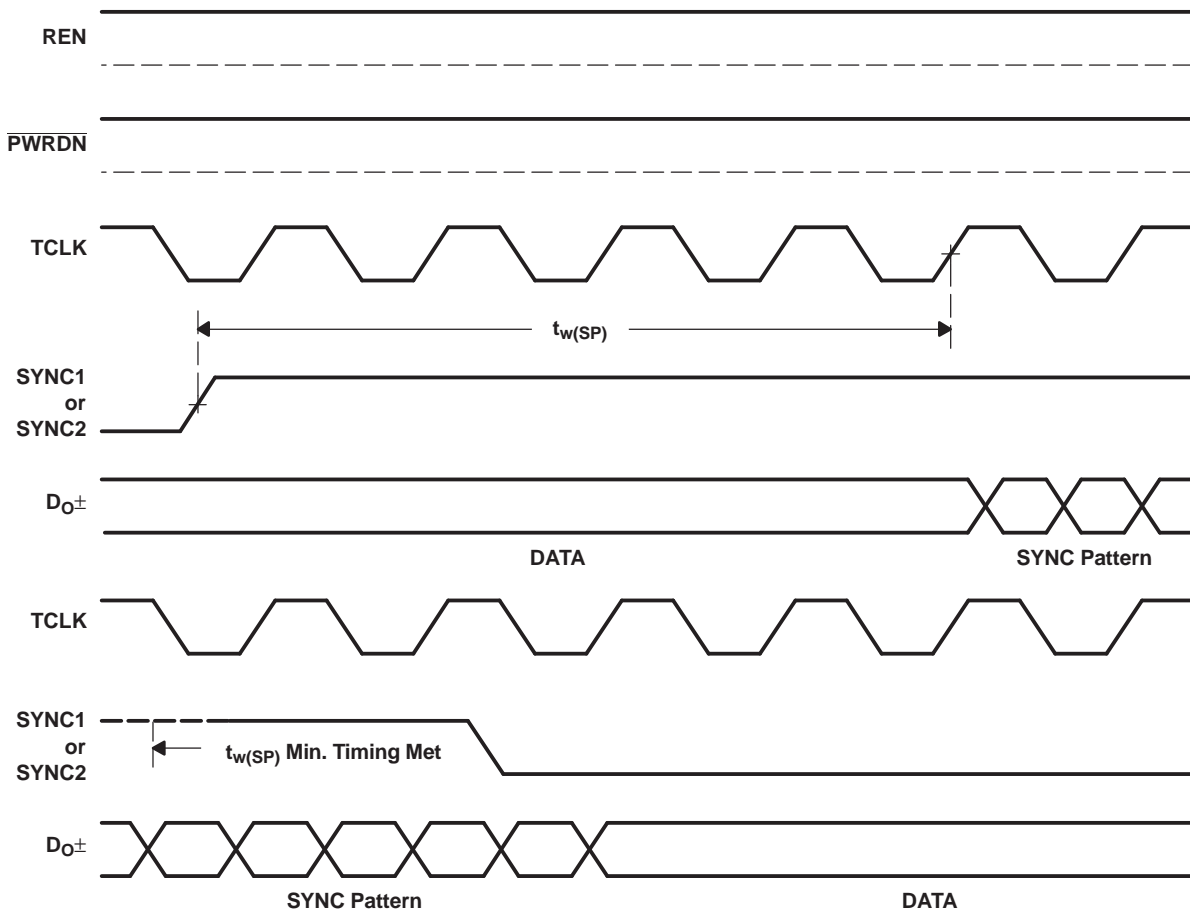

Figure 12. SYNC Timing Delays

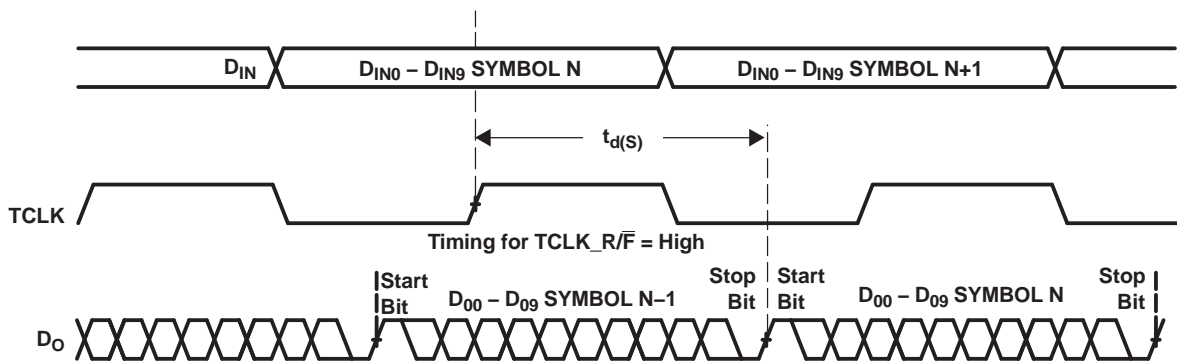

Figure 13. Serializer Delay

TIMING DIAGRAMS AND TEST CIRCUITS (continued)

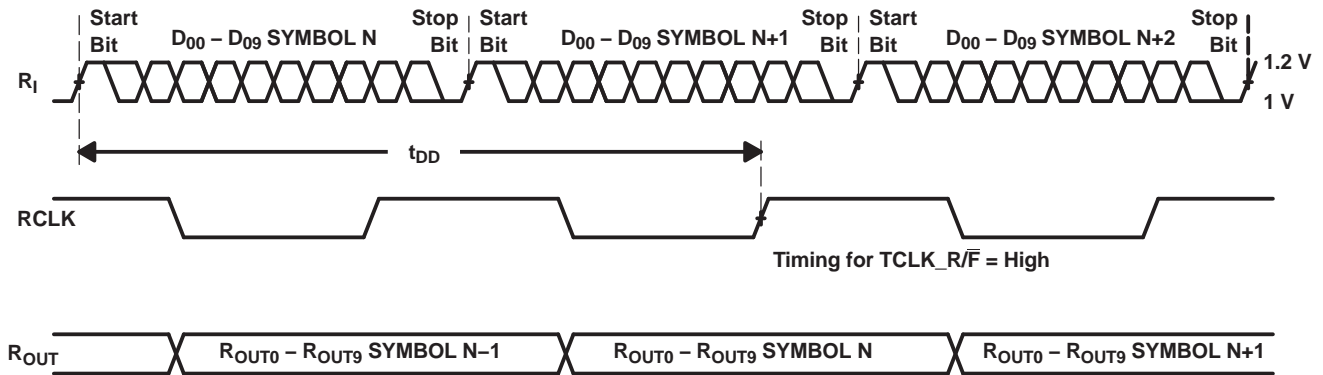

Figure 14. Deserializer Delay

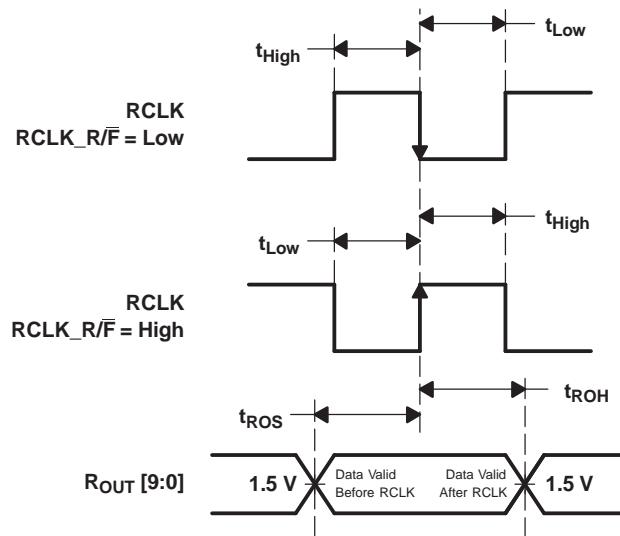

Figure 15. Deserializer Data Valid Out Times

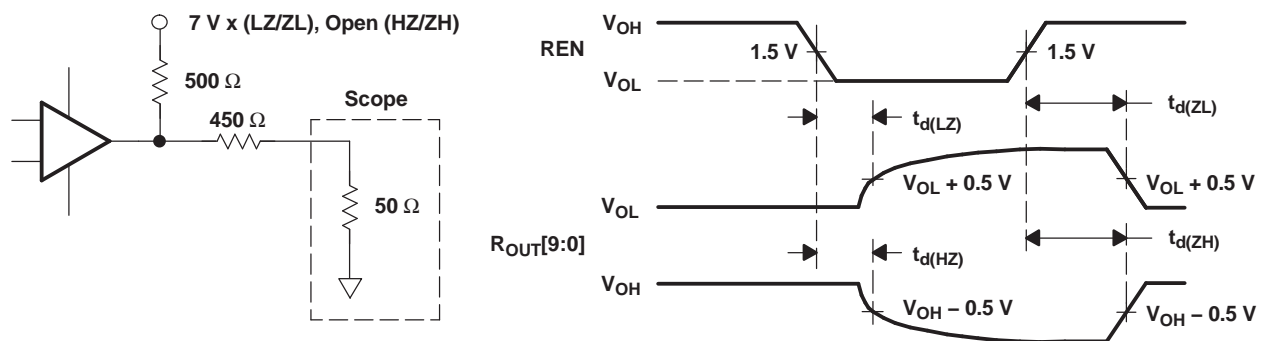

Figure 16. Deserializer High-Impedance State Test Circuit and Timing

TIMING DIAGRAMS AND TEST CIRCUITS (continued)

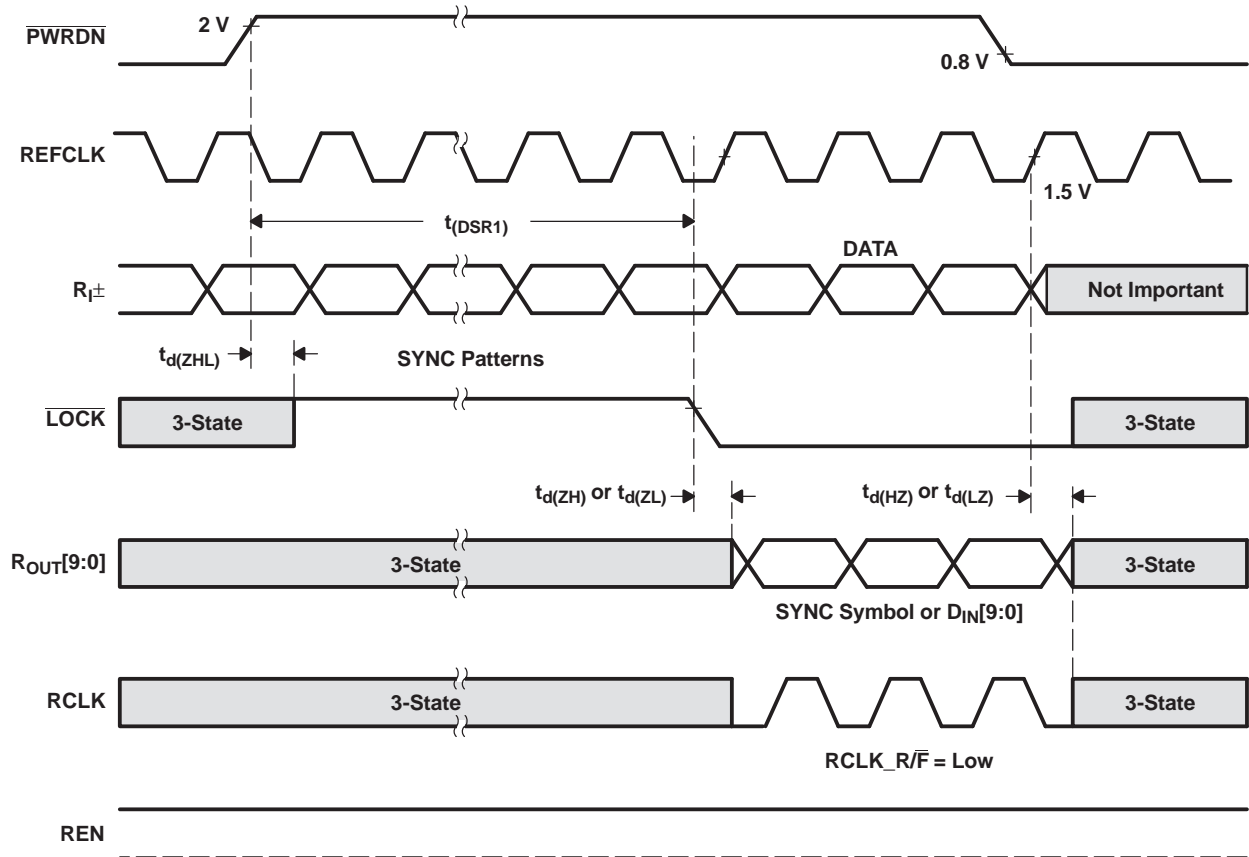

Figure 17. Deserializer PLL Lock Times and PWRDN 3-State Delays

TIMING DIAGRAMS AND TEST CIRCUITS (continued)

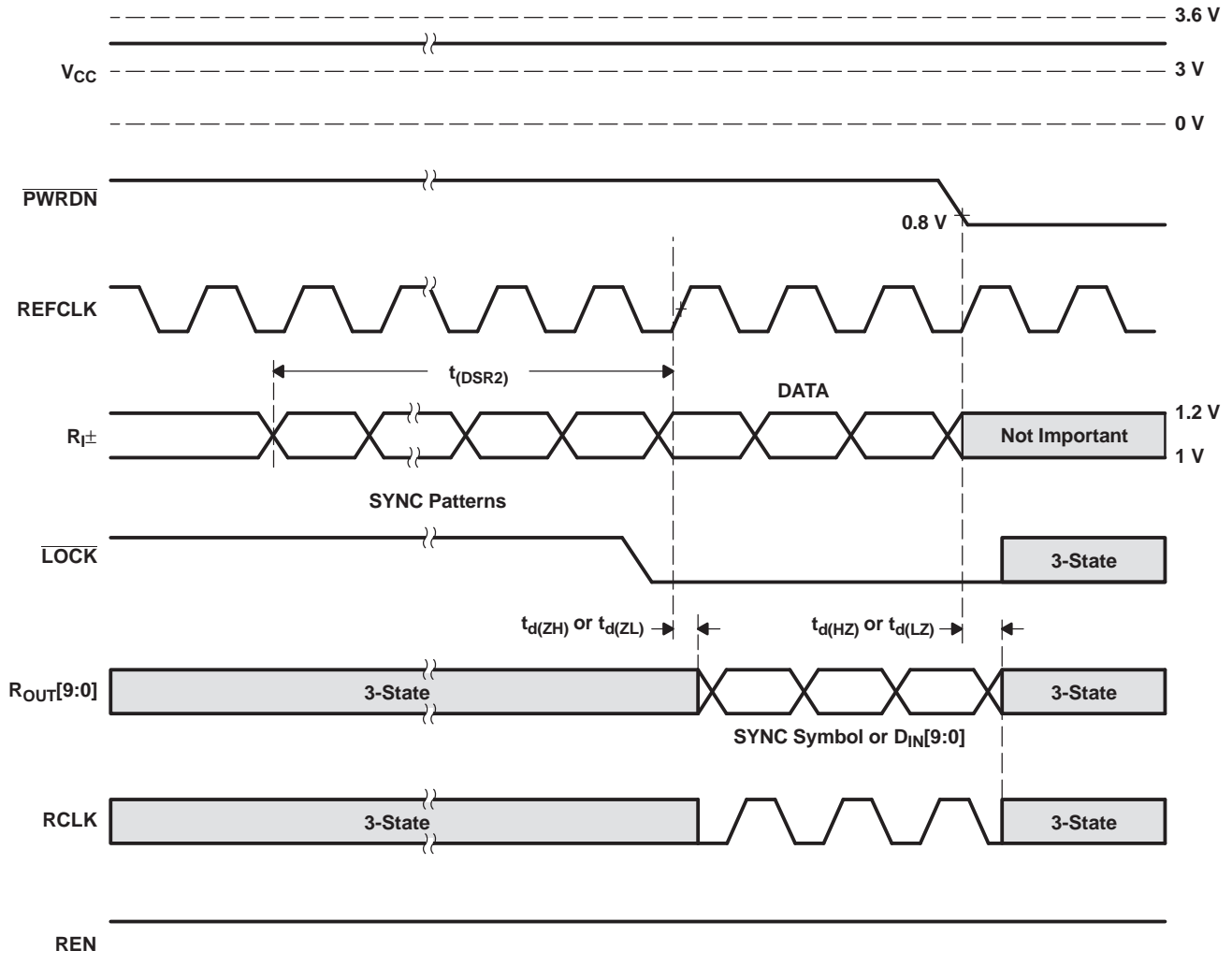
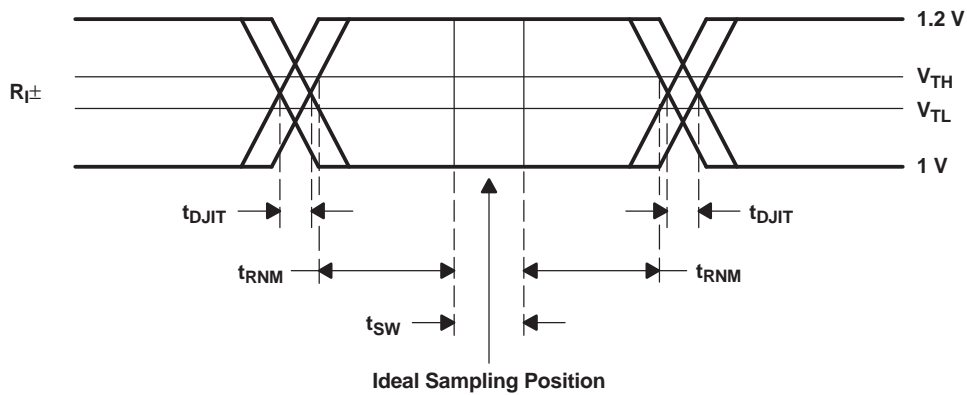

Figure 18. Deserializer PLL Lock Time From SyncPAT



t_{sw} : Setup and Hold Time (Internal Data Sampling Window)
 t_{DJIT} : Serializer Output Bit Position Jitter That Results From Jitter on TCLK
 t_{RNM} : Receiver Noise Margin Time

Figure 19. Receiver LVDS Input Skew Margin

TIMING DIAGRAMS AND TEST CIRCUITS (continued)

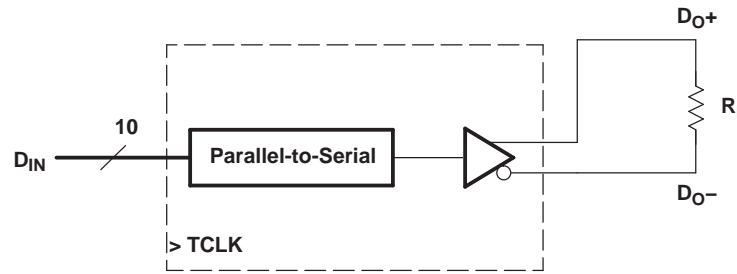

$V_{OD} = (D_{O+}) - (D_{O-})$
 Differential Output Signal Is Shown as $(D_{O+}) - (D_{O-})$

Figure 20. V_{OD} Diagram

DEVICE STARTUP PROCEDURE

It is recommended that the PWRDNB pin on both the SN65LV1023A and the SN65LV1224B device be held to a logic LOW level until after the power supplies have powered up to at least 3 V as shown in [Figure 21](#).

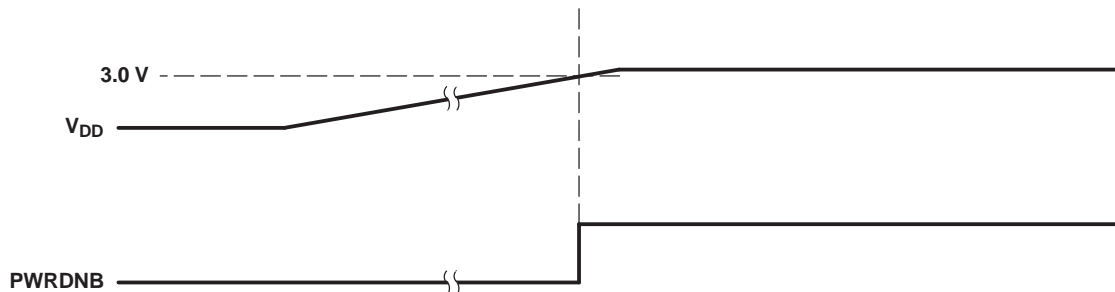

Figure 21. Device Startup

APPLICATION INFORMATION

DIFFERENTIAL TRACES AND TERMINATION

The performance of the SN65LV1023A/SN65LV1224B is affected by the characteristics of the transmission medium. Use controlled-impedance media and termination at the receiving end of the transmission line with the media's characteristic impedance.

Use balanced cables such as twisted pair or differential traces that are ran close together. A balanced cable picks up noise together and appears to the receiver as common mode. Differential receivers reject common-mode noise. Keep cables or traces matched in length to help reduce skew.

Running the differential traces close together helps cancel the external magnetic field, as well as maintain a constant impedance. Avoiding sharp turns and reducing the number of vias also helps.

TOPOLOGIES

There are several topologies that the serializers can operate. Three common examples are shown below.

Figure 22 shows an example of a single-terminated point-to-point connection. Here a single termination resistor is located at the deserializer end. The resistor value should match that of the characteristic impedance of the cable or PC board traces. The total load seen by the serializer is $100\ \Omega$. Double termination can be used and typically reduces reflections compared with single termination. However, it also reduces the differential output voltage swing.

AC-coupling is only recommended if the parallel TX data stream is encoded to achieve a dc-balanced data stream. Otherwise the ac-capacitors can induce common mode voltage drift due to the dc-unbalanced data stream.

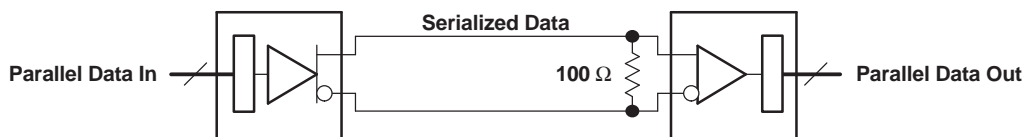

Figure 22. Single-Terminated Point-to-Point Connection

Figure 23 shows an example of a multidrop configuration. Here there is one transmitter broadcasting data to multiple receivers. A $50\text{-k}\Omega$ resistor at the far end terminates the bus.

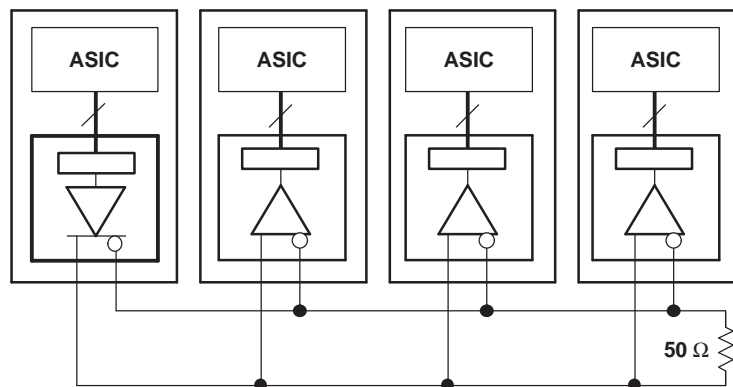

Figure 23. Multidrop Configuration

Figure 24 shows an example of multiple serializers and deserializers on the same differential bus, such as in a backplane. This is a multipoint configuration. In this situation, the characteristic impedance of the bus can be significantly less due to loading. Termination resistors that match the loaded characteristic impedance are required at each end of the bus. The total load seen by the serializer in this example is $27\ \Omega$.

APPLICATION INFORMATION (continued)

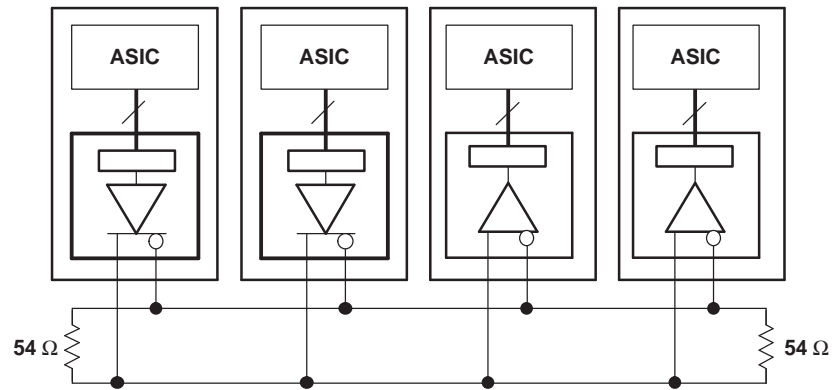

Figure 24. Multiple Serializers and Deserializers on the Same Differential Bus

TAPE AND REEL INFORMATION



QUADRANT ASSIGNMENTS FOR PIN 1 ORIENTATION IN TAPE



*All dimensions are nominal

Device	Package Type	Package Drawing	Pins	SPQ	Reel Diameter (mm)	Reel Width W1 (mm)	A0 (mm)	B0 (mm)	K0 (mm)	P1 (mm)	W (mm)	Pin1 Quadrant
SN65LV1224BMBREP	SSOP	DB	28	2000	330.0	16.4	8.1	10.4	2.5	12.0	16.0	Q1

TAPE AND REEL BOX DIMENSIONS



*All dimensions are nominal

Device	Package Type	Package Drawing	Pins	SPQ	Length (mm)	Width (mm)	Height (mm)
SN65LV1224BMDREP	SSOP	DB	28	2000	350.0	350.0	43.0

DB0028A



PACKAGE OUTLINE

SSOP - 2 mm max height

SMALL OUTLINE PACKAGE

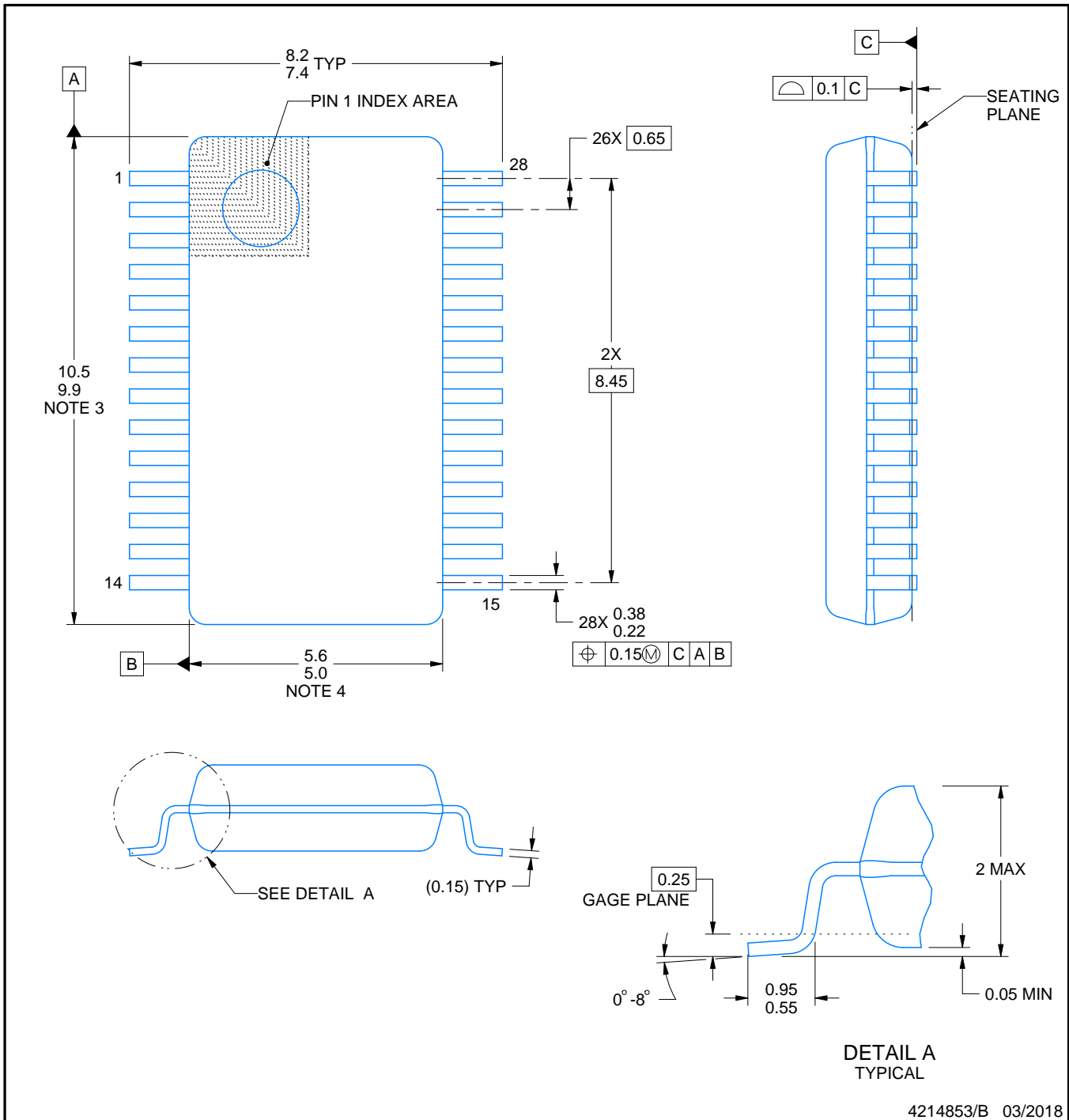

4214853/B 03/2018

NOTES:

1. All linear dimensions are in millimeters. Any dimensions in parenthesis are for reference only. Dimensioning and tolerancing per ASME Y14.5M.
2. This drawing is subject to change without notice.
3. This dimension does not include mold flash, protrusions, or gate burrs. Mold flash, protrusions, or gate burrs shall not exceed 0.15 mm per side.
4. This dimension does not include interlead flash. Interlead flash shall not exceed 0.25 mm per side.
5. Reference JEDEC registration MO-150.

EXAMPLE BOARD LAYOUT

DB0028A

SSOP - 2 mm max height

SMALL OUTLINE PACKAGE

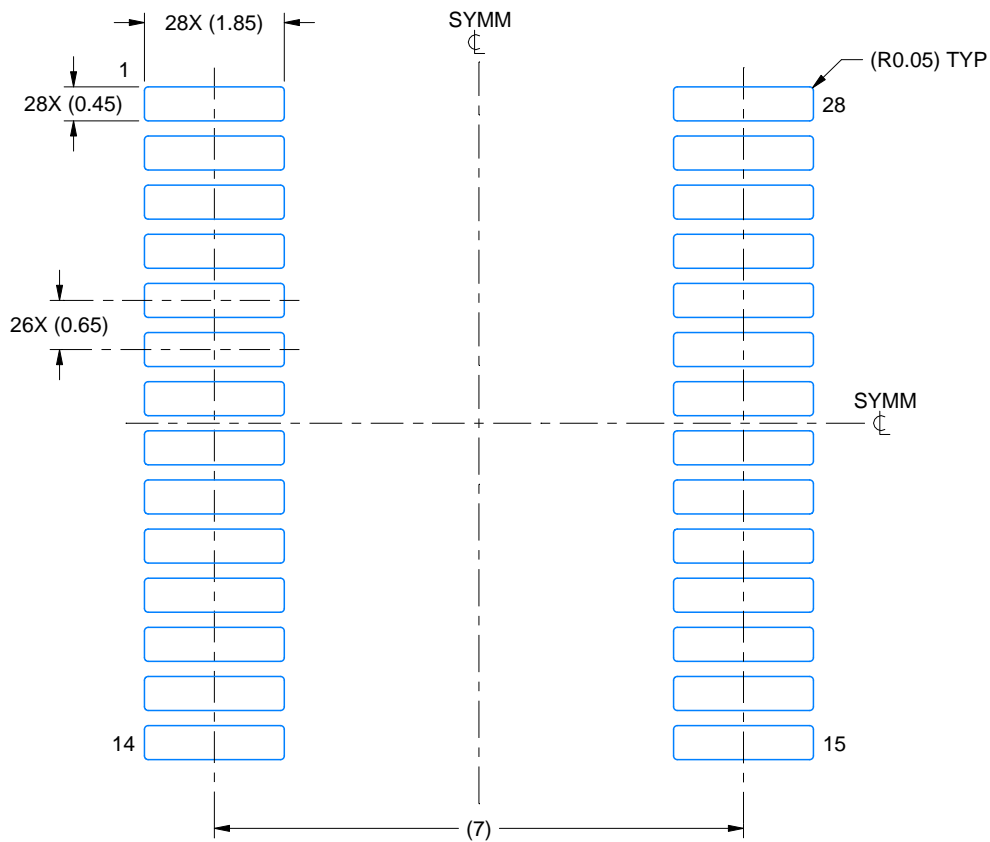

LAND PATTERN EXAMPLE
EXPOSED METAL SHOWN
SCALE: 10X

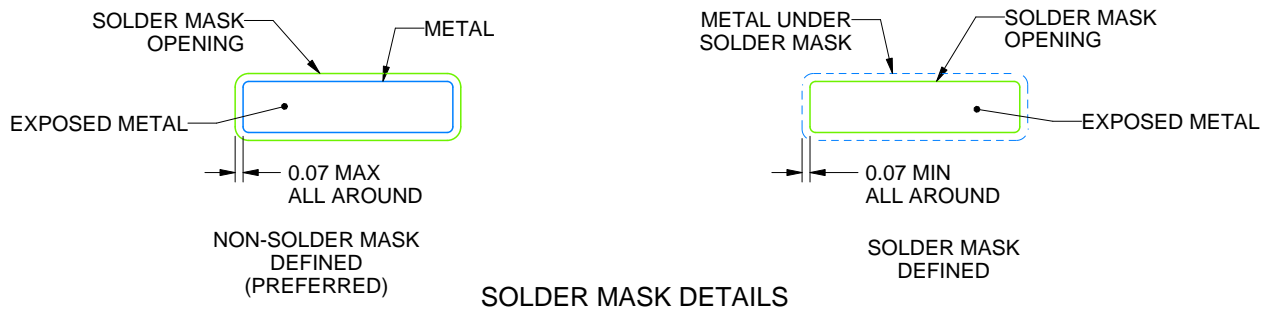

4214853/B 03/2018

NOTES: (continued)

- 6. Publication IPC-7351 may have alternate designs.
- 7. Solder mask tolerances between and around signal pads can vary based on board fabrication site.

EXAMPLE STENCIL DESIGN

DB0028A

SSOP - 2 mm max height

SMALL OUTLINE PACKAGE

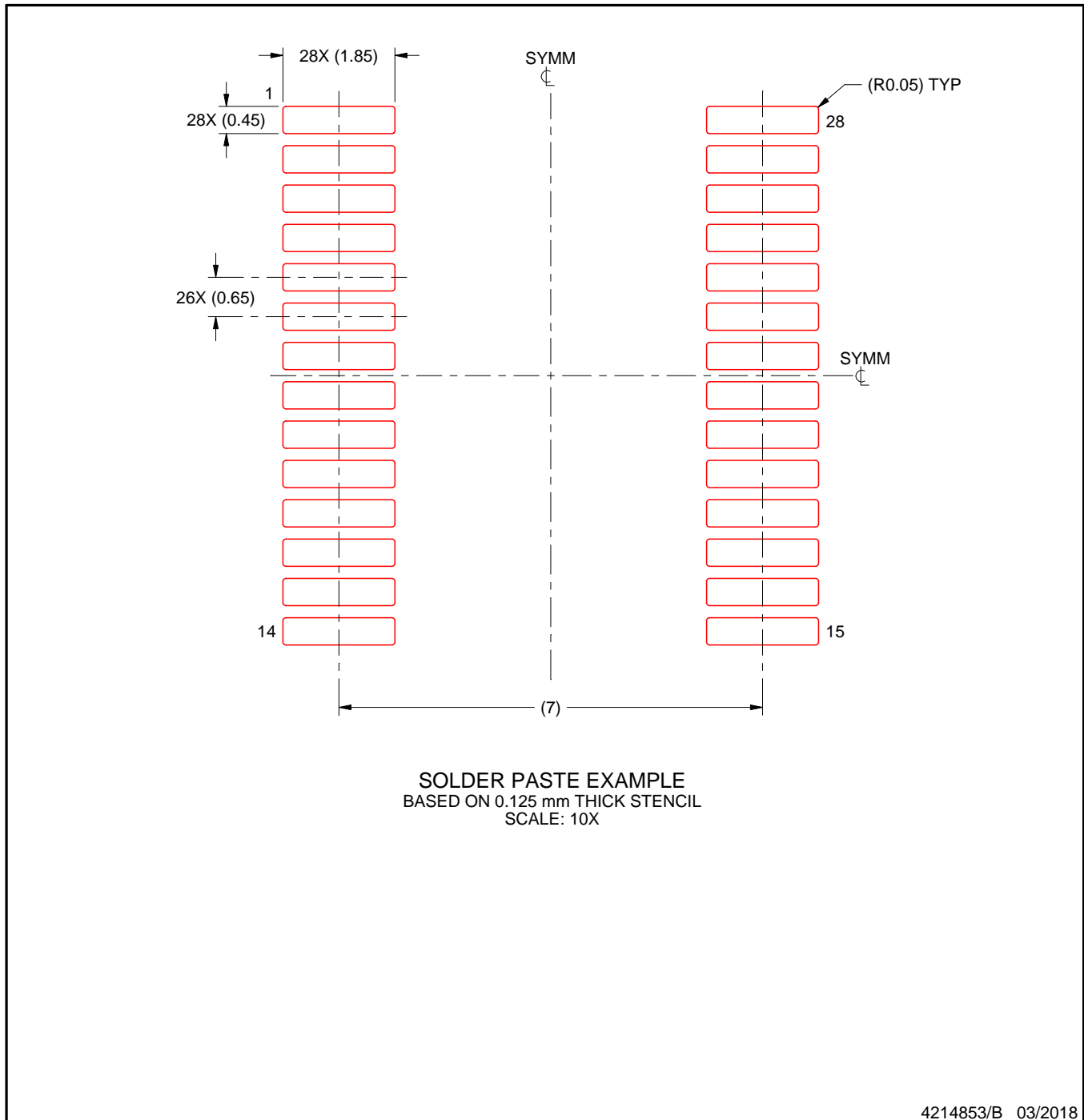

NOTES: (continued)

8. Laser cutting apertures with trapezoidal walls and rounded corners may offer better paste release. IPC-7525 may have alternate design recommendations.
9. Board assembly site may have different recommendations for stencil design.

IMPORTANT NOTICE AND DISCLAIMER

TI PROVIDES TECHNICAL AND RELIABILITY DATA (INCLUDING DATASHEETS), DESIGN RESOURCES (INCLUDING REFERENCE DESIGNS), APPLICATION OR OTHER DESIGN ADVICE, WEB TOOLS, SAFETY INFORMATION, AND OTHER RESOURCES "AS IS" AND WITH ALL FAULTS, AND DISCLAIMS ALL WARRANTIES, EXPRESS AND IMPLIED, INCLUDING WITHOUT LIMITATION ANY IMPLIED WARRANTIES OF MERCHANTABILITY, FITNESS FOR A PARTICULAR PURPOSE OR NON-INFRINGEMENT OF THIRD PARTY INTELLECTUAL PROPERTY RIGHTS.

These resources are intended for skilled developers designing with TI products. You are solely responsible for (1) selecting the appropriate TI products for your application, (2) designing, validating and testing your application, and (3) ensuring your application meets applicable standards, and any other safety, security, or other requirements. These resources are subject to change without notice. TI grants you permission to use these resources only for development of an application that uses the TI products described in the resource. Other reproduction and display of these resources is prohibited. No license is granted to any other TI intellectual property right or to any third party intellectual property right. TI disclaims responsibility for, and you will fully indemnify TI and its representatives against, any claims, damages, costs, losses, and liabilities arising out of your use of these resources.

TI's products are provided subject to TI's Terms of Sale (www.ti.com/legal/termsofsale.html) or other applicable terms available either on ti.com or provided in conjunction with such TI products. TI's provision of these resources does not expand or otherwise alter TI's applicable warranties or warranty disclaimers for TI products.

Mailing Address: Texas Instruments, Post Office Box 655303, Dallas, Texas 75265
Copyright © 2019, Texas Instruments Incorporated