



CT3061-5L, CT3062-5L, CT3063-5L

CT3081-5L, CT3082-5L, CT3083-5L

600V/800V Zero Cross 5-Pin Phototriac Optocoupler

Features

- High isolation 5000 VRMS
- Peak Breakdown Voltage
 - 600V – CT3061-5L,CT3062-5L,CT3063-5L
 - 800V – CT3081-5L,CT3082-5L,CT3083-5L
- Temperature range - 55 °C to 100 °C
- Regulatory Approvals
 - UL - UL1577 (E364000)
 - VDE - EN60747-5-5(VDE0884-5)
 - CQC – GB4943.1, GB8898
 - IEC60065, IEC60950

Description

The CT3061-5L, CT3062-5L, CT3063-5L, CT3081-5L, CT3082-5L and CT3083-5L series consists of a Zero Cross Photo Triac optically coupled to a gallium arsenide Infrared-emitting diode in a 5-lead DIP package.

Applications

- Motor Controls
- Lamp ballasts
- Static AC Power Switch
- Solenoid/ Valve Control

Package Outline

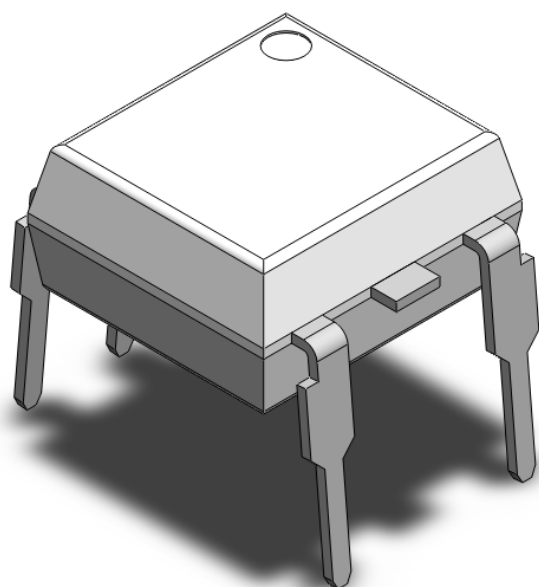

Note: Different lead forming options available. See package dimension.

Schematic

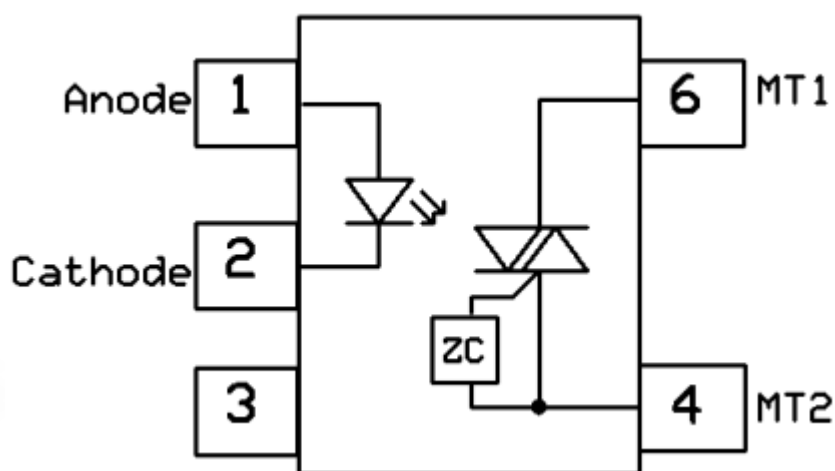



CT3061-5L, CT3062-5L, CT3063-5L

CT3081-5L, CT3082-5L, CT3083-5L

600V/800V Zero Cross 5-Pin Phototriac Optocoupler

Absolute Maximum Rating at 25°C

Symbol	Parameters	Ratings	Units	Notes
V _{ISO}	Isolation voltage	5000	V _{RMS}	
T _{OPR}	Operating temperature	-55 ~ +100	°C	
T _{STG}	Storage temperature	-55 ~ +150	°C	
T _{SOL}	Soldering temperature	260	°C	
Emitter				
I _F	Forward current	60	mA	
I _{F(TRANS)}	Peak transient current (≤1μs P.W,300pps)	1	A	
V _R	Reverse voltage	6	V	
P _D	Power dissipation	100	mW	
Detector				
P _D	Power dissipation	300	mW	
V _{DRM}	Off-State Output Terminal Voltage	CT3061-5L,3062-5L,3063-5L	600	V
		CT3081-5L,3082-5L,3083-5L	800	V
I _{TSM}	Peak Repetitive Surge Current	1	A	



CT3061-5L, CT3062-5L, CT3063-5L

CT3081-5L, CT3082-5L, CT3083-5L

600V/800V Zero Cross 5-Pin Phototriac Optocoupler

Electrical Characteristics $T_A = 25^\circ\text{C}$ (unless otherwise specified)

Emitter Characteristics

Symbol	Parameters	Test Conditions	Min	Typ	Max	Units	Notes
V_F	Forward voltage	$I_F = 10\text{mA}$		1.24	1.4	V	
I_R	Reverse Current	$V_R = 6\text{V}$	-	-	5	μA	
C_{IN}	Input Capacitance	$f = 1\text{MHz}$	-	45	-	pF	

Detector Characteristics

Symbol	Parameters	Test Conditions	Min	Typ	Max	Units	Notes	
I_{DRM1}	Peak Blocking Current	$I_F = 0\text{mA}$, $V_{DRM} = \text{Rated } V_{DRM}$	-	-	500	nA		
I_{DRM2}	Inhibit Leakage Current	$I_F = \text{Rated } I_{FT}$, $V_{DRM} = \text{Rated } V_{DRM}$			500	μA		
V_{INH}	Inhibit Voltage	$I_F = \text{Rated } I_{FT}$			20	V		
V_{TM}	Peak On-State Voltage	$I_F = \text{Rated } I_{FT}$, $I_{TM} = 100\text{mA}$	-	-	3	V		
dv/dt	Critical Rate of Rise off-State Voltage	CT3061-5L, CT3062-5L, CT3063-5L	$V_{PEAK} = \text{Rated } V_{DRM}$	1000	-	-	$\text{V}/\mu\text{s}$	
		CT3081-5L, CT3082-5L, CT3083-5L		600	-	-		

Transfer Characteristics

Symbol	Parameters	Test Conditions	Min	Typ	Max	Units	Notes
I_{FT}	Input Trigger Current	CT3061-5L, CT3081-5L	-	-	15	mA	
		CT3062-5L, CT3082-5L	-	-	10		
		CT3063-5L, CT3083-5L	-	-	5		
I_H	Holding Current	Terminal Voltage = 3V	-	380	-	μA	
R_{IO}	Isolation Resistance	$V_{IO} = 500\text{V}_{DC}$	1×10^{11}			Ω	
C_{IO}	Isolation Capacitance	$f = 1\text{MHz}$		0.25		pF	



Typical Characteristic Curve

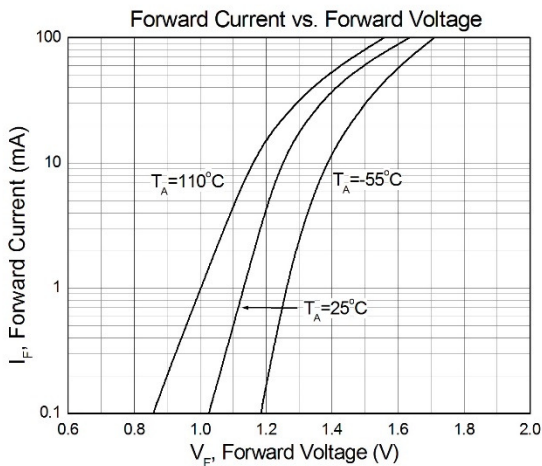

Figure 1

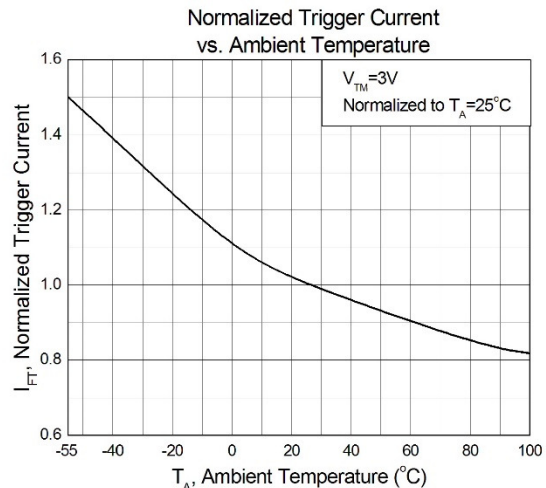

Figure 2

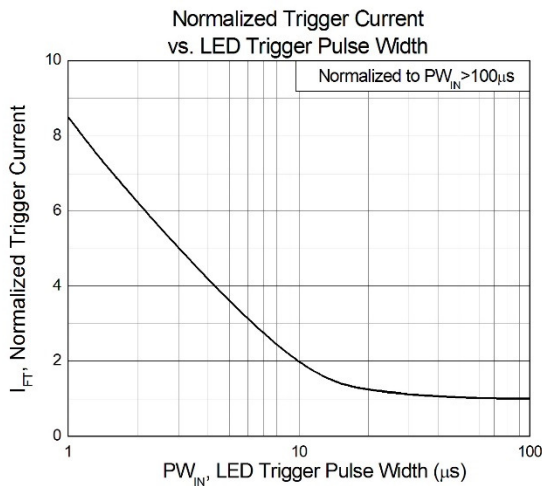

Figure 3

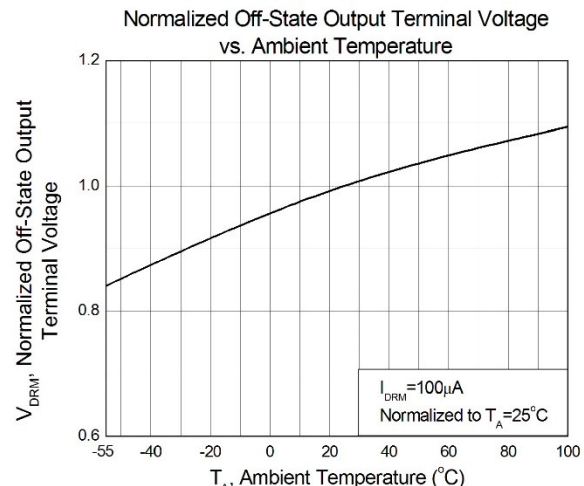

Figure 4

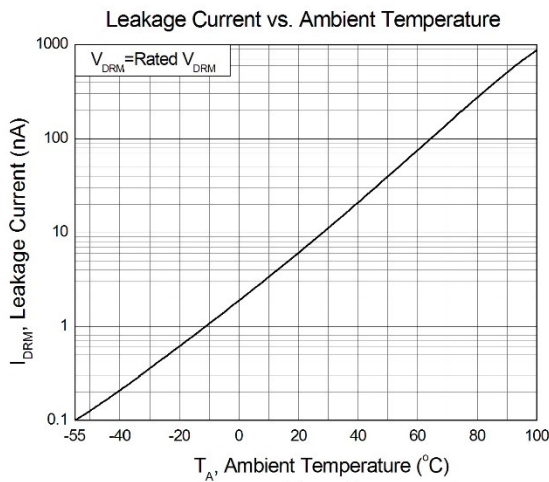

Figure 5

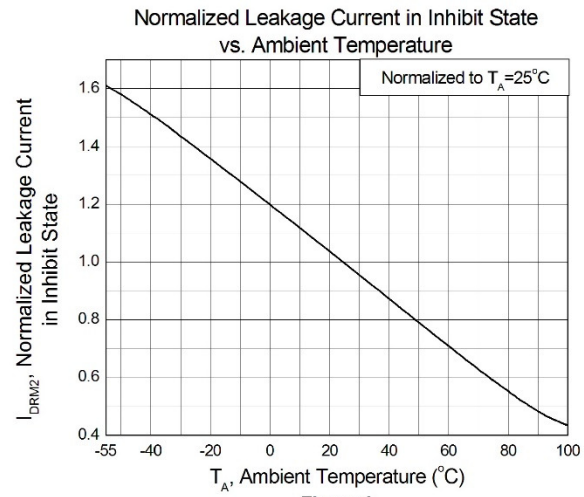

Figure 6



CT3061-5L, CT3062-5L, CT3063-5L

CT3081-5L, CT3082-5L, CT3083-5L

600V/800V Zero Cross 5-Pin Phototriac Optocoupler

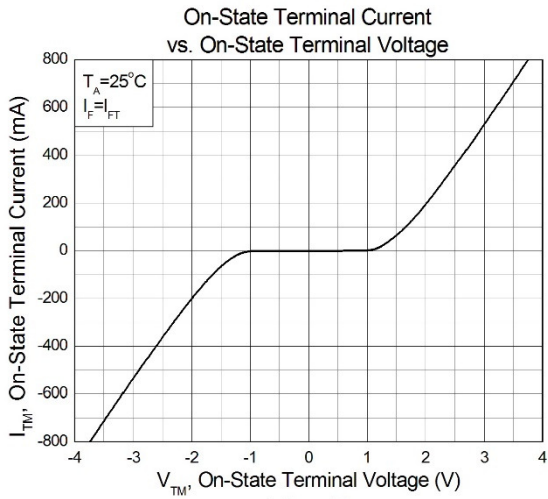

Figure 7

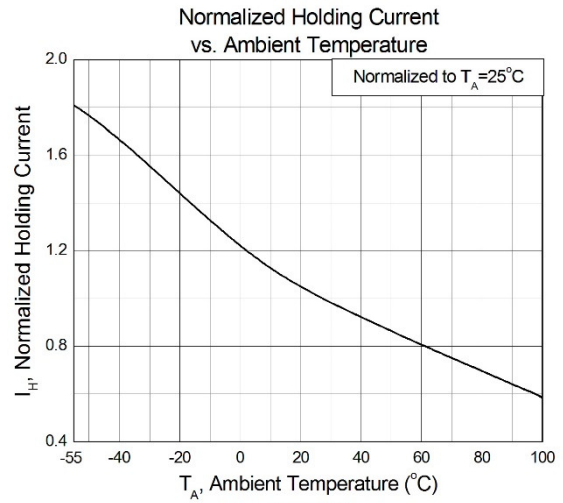

Figure 8

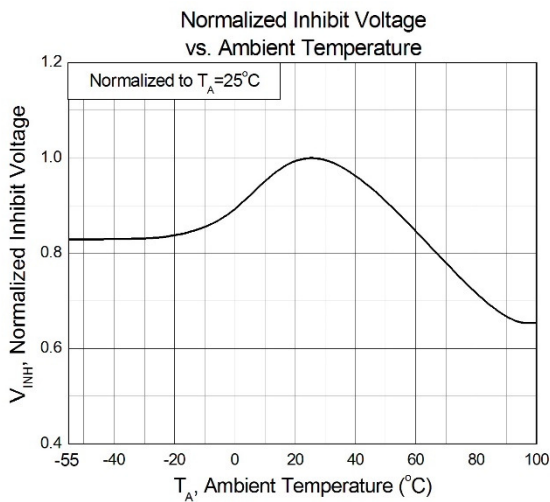

Figure 9



CT3061-5L, CT3062-5L, CT3063-5L

CT3081-5L, CT3082-5L, CT3083-5L

600V/800V Zero Cross 5-Pin Phototriac Optocoupler

Package Dimension *Dimensions in mm unless otherwise stated*

Standard DIP – Through Hole

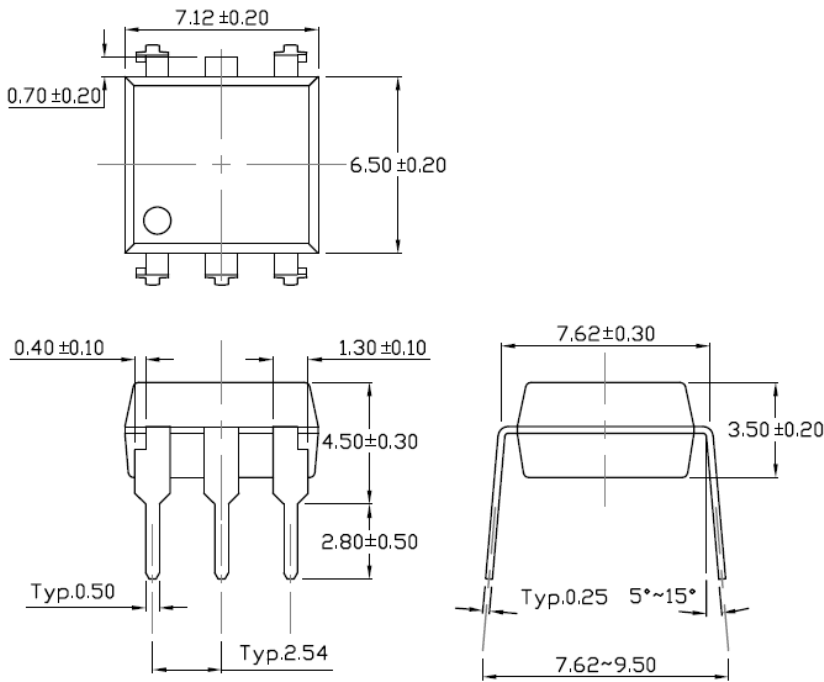

Wide Lead Forming – Through Hole (M Type)

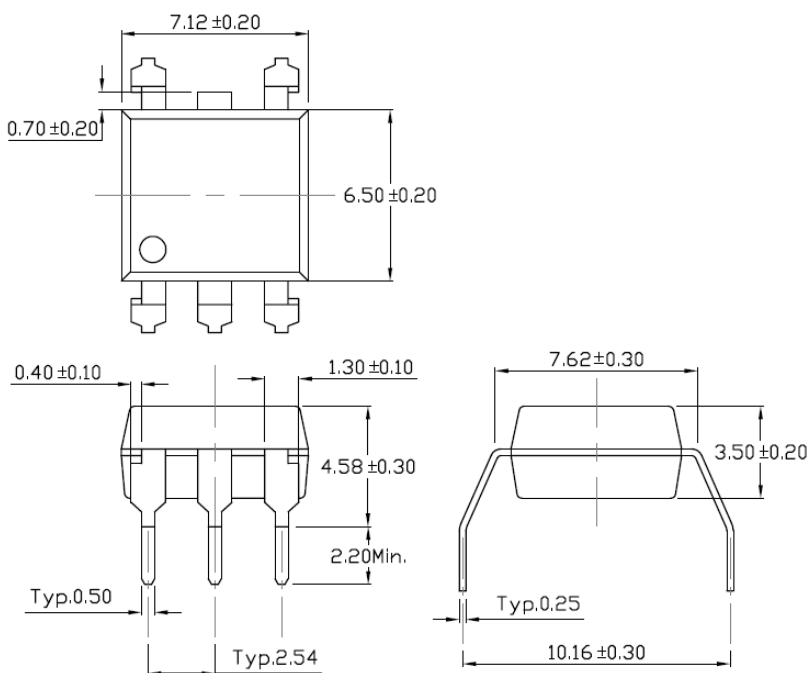



CT3061-5L, CT3062-5L, CT3063-5L

CT3081-5L, CT3082-5L, CT3083-5L

600V/800V Zero Cross 5-Pin Phototriac Optocoupler

Surface Mount Lead Forming (S Type)

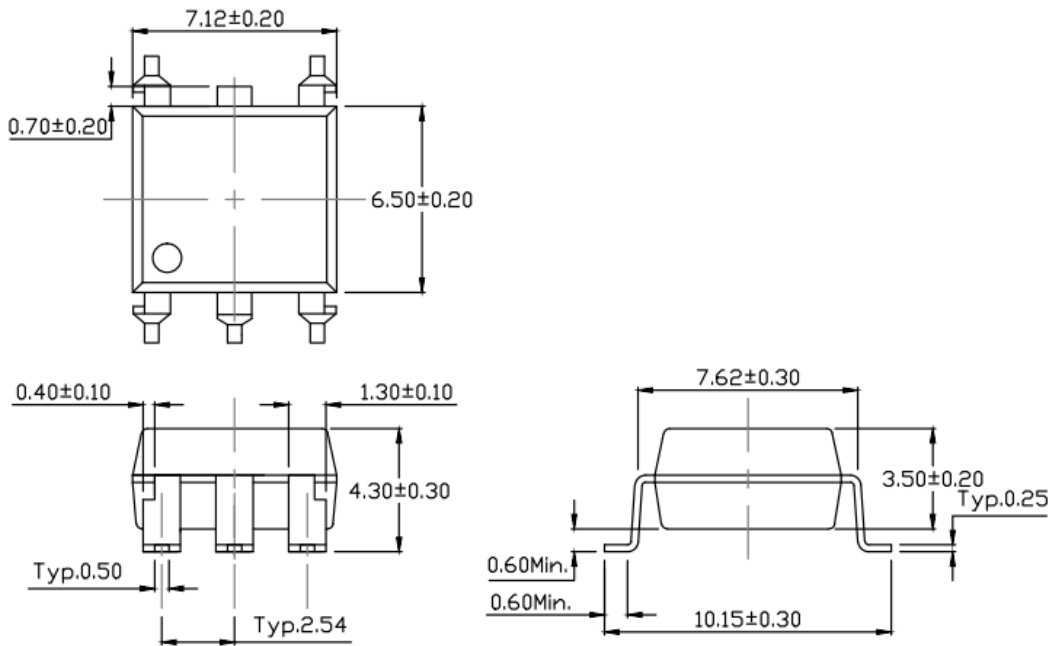

Marking Information

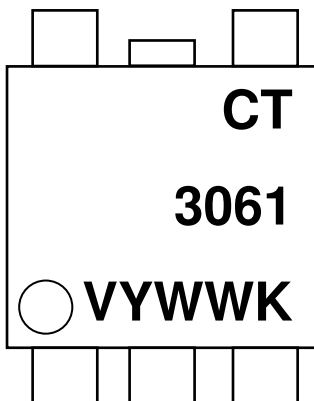

Note:

- CT : Denotes "CT Micro"
- 3061 : Part Number
- V : VDE Option
- Y : Fiscal Year
- WW : Work Week
- K : Manufacturing Code



CT3061-5L, CT3062-5L, CT3063-5L

CT3081-5L, CT3082-5L, CT3083-5L

600V/800V Zero Cross 5-Pin Phototriac Optocoupler

Ordering Information

CT306X(Y)-5L-G, CT308X(Y)-5L-G

X = Part No.(X=1,2,3)

Y = Lead form option (S, M or none)

G= Material option (G: Green, None: Non-green)

Option	Description	Quantity
None	Standard 5 Pin Dip	50Units/Tube
M	Gullwing (400mil) Lead Forming	50Units/Tube
S(T1)	Surface Mount Lead Forming – With Option 1 Taping	1000 Units/Reel
S(T2)	Surface Mount Lead Forming – With Option 2 Taping	1000 Units/Reel

Carrier Tape Specifications *Dimensions in mm unless otherwise stated*

Option S(T1)

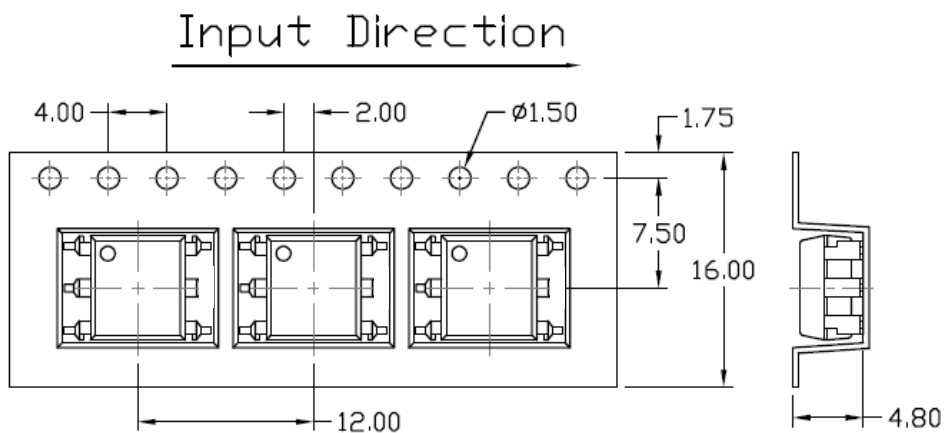

Option S(T2)

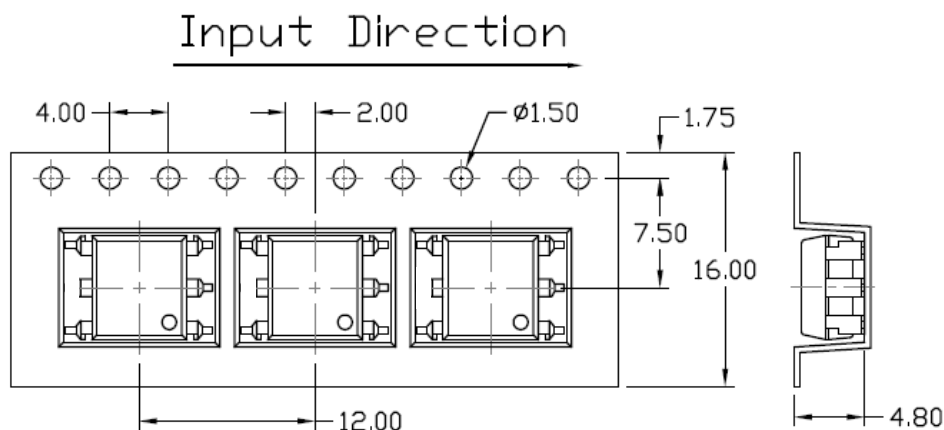



CT3061-5L, CT3062-5L, CT3063-5L

CT3081-5L, CT3082-5L, CT3083-5L

600V/800V Zero Cross 5-Pin Phototriac Optocoupler

Reflow Profile

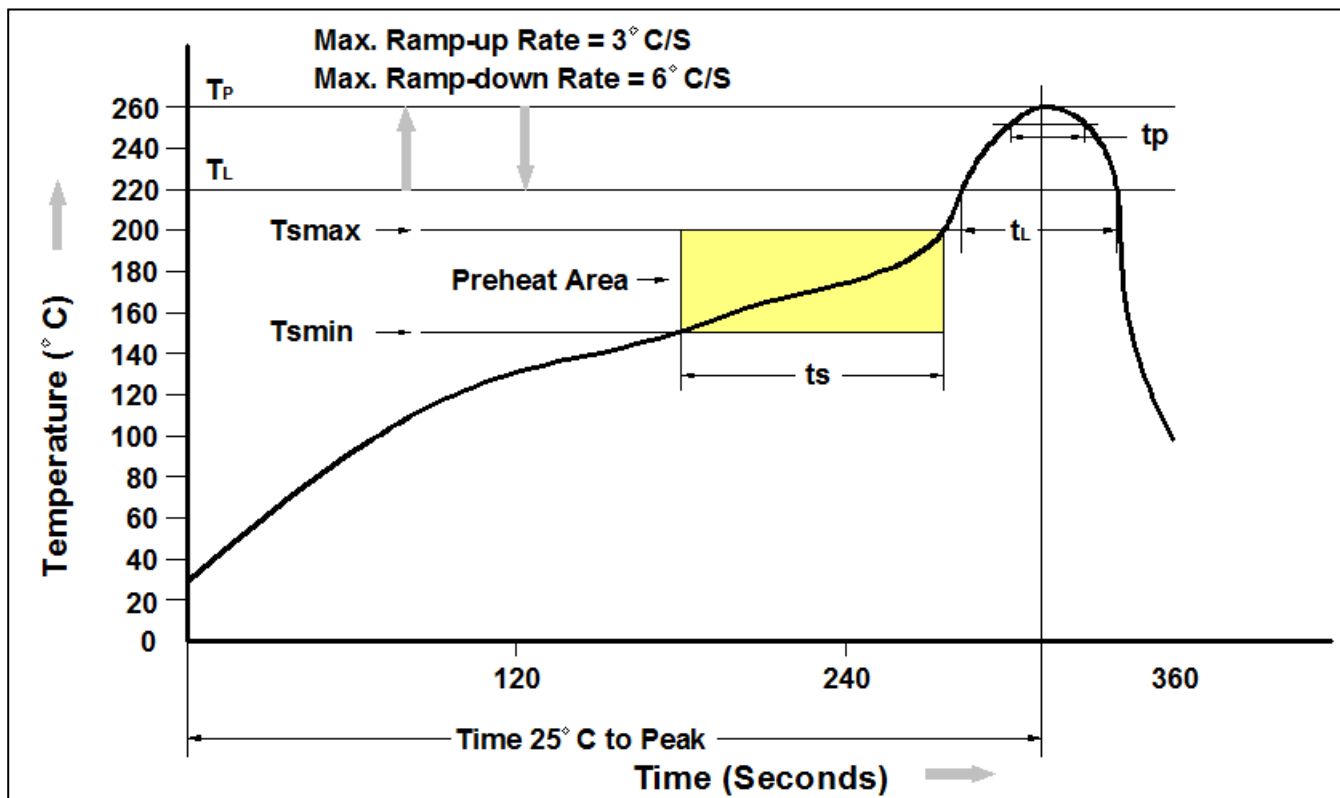

Profile Feature	Pb-Free Assembly Profile
Temperature Min. (T _{smin})	150 °C
Temperature Max. (T _{smax})	200 °C
Time (t _s) from (T _{smin} to T _{smax})	60-120 seconds
Ramp-up Rate (t _L to t _P)	3°C/second max.
Liquidous Temperature (T _L)	217 °C
Time (t _L) Maintained Above (T _L)	60 – 150 seconds
Peak Body Package Temperature	260 °C +0 °C / -5 °C
Time (t _P) within 5 °C of 260 °C	30 seconds
Ramp-down Rate (T _P to T _L)	6°C/second max
Time 25 °C to Peak Temperature	8 minutes max.



CT3061-5L, CT3062-5L, CT3063-5L

CT3081-5L, CT3082-5L, CT3083-5L

600V/800V Zero Cross 5-Pin Phototriac Optocoupler

DISCLAIMER

CT MICRO RESERVES THE RIGHT TO MAKE CHANGES WITHOUT FURTHER NOTICE TO ANY PRODUCTS HEREIN TO IMPROVE RELIABILITY, FUNCTION OR DESIGN. CT MICRO DOES NOT ASSUME ANY LIABILITY ARISING OUT OF THE APPLICATION OR USE OF ANY PRODUCT OR CIRCUIT DESCRIBED HEREIN; NEITHER DOES IT CONVEY ANY LICENSE UNDER ITS PATENT RIGHTS, NOR THE RIGHTS OF OTHERS.

DISCOLORATION MIGHT OCCUR ON THE PACKAGE SURFACE AFTER SOLDERING, REFLOW OR LONG TERM USE. THIS DOES NOT IMPACT THE PRODUCT PERFORMANCE NOR THE PRODUCT RELIABILITY.

CT MICRO ARE NOT AUTHORIZED FOR USE AS CRITICAL COMPONENTS IN LIFE SUPPORT DEVICES OR SYSTEMS WITHOUT EXPRESS WRITTEN APPROVAL OF CT MICRO INTERNATIONAL CORPORATION.

- 1. Life support devices or systems are devices or systems which, (a) are intended for surgical implant into the body, or (b) support or sustain life, or (c) whose failure to perform when properly used in accordance with instruction for use provided in the labelling, can be reasonably expected to result in significant injury to the user.*
- 2. A critical component is any component of a life support device or system whose failure to perform can be reasonably expected to cause the failure of the life support device or system, or to affect its safety or effectiveness.*