

LM339, LM239, LM2901, LM2901V, NCV2901, MC3302

Single Supply Quad Comparators

These comparators are designed for use in level detection, low-level sensing and memory applications in consumer, automotive, and industrial electronic applications.

Features

- Single or Split Supply Operation
- Low Input Bias Current: 25 nA (Typ)
- Low Input Offset Current: ± 5.0 nA (Typ)
- Low Input Offset Voltage
- Input Common Mode Voltage Range to GND
- Low Output Saturation Voltage: 130 mV (Typ) @ 4.0 mA
- TTL and CMOS Compatible
- ESD Clamps on the Inputs Increase Reliability without Affecting Device Operation
- NCV Prefix for Automotive and Other Applications Requiring Site and Control Changes
- Pb-Free Packages are Available



ON Semiconductor®

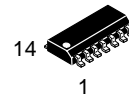

SOIC-14
D SUFFIX
CASE 751A

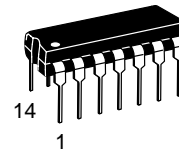

PDIP-14
N, P SUFFIX
CASE 646

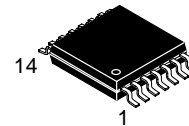

TSSOP-14
DTB SUFFIX
CASE 948G

PIN CONNECTIONS

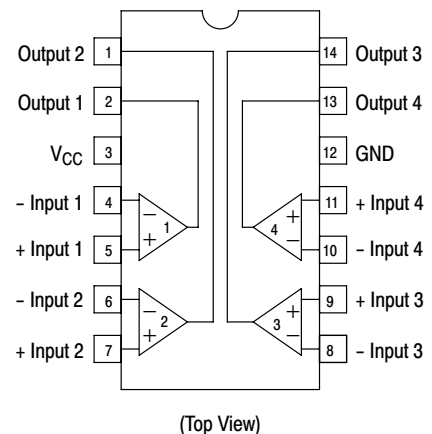

ORDERING INFORMATION

See detailed ordering and shipping information in the package dimensions section on page 6 of this data sheet.

DEVICE MARKING INFORMATION

See general marking information in the device marking section on page 8 of this data sheet.

LM339, LM239, LM2901, LM2901V, NCV2901, MC3302

MAXIMUM RATINGS

Rating	Symbol	Value	Unit
Power Supply Voltage LM239/LM339/LM2901, V MC3302	V_{CC}	+36 or ± 18 +30 or ± 15	Vdc
Input Differential Voltage Range LM239/LM339/LM2901, V MC3302	V_{IDR}	36 30	Vdc
Input Common Mode Voltage Range	V_{ICMR}	-0.3 to V_{CC}	Vdc
Output Short Circuit to Ground (Note 1)	I_{SC}	Continuous	
Power Dissipation @ $T_A = 25^\circ\text{C}$ Plastic Package Derate above 25°C	P_D $1/R_{\theta JA}$	1.0 8.0	W mW/ $^\circ\text{C}$
Junction Temperature	T_J	150	$^\circ\text{C}$
Operating Ambient Temperature Range LM239 MC3302 LM2901 LM2901V, NCV2901 LM339	T_A	-25 to +85 -40 to +85 -40 to +105 -40 to +125 0 to +70	$^\circ\text{C}$
Storage Temperature Range	T_{stg}	-65 to +150	$^\circ\text{C}$
ESD Protection at any Pin (Note 2) Human Body Model Machine Model	V_{ESD}	1500 200	V

Stresses exceeding Maximum Ratings may damage the device. Maximum Ratings are stress ratings only. Functional operation above the Recommended Operating Conditions is not implied. Extended exposure to stresses above the Recommended Operating Conditions may affect device reliability.

- The maximum output current may be as high as 20 mA, independent of the magnitude of V_{CC} . Output short circuits to V_{CC} can cause excessive heating and eventual destruction.
- V_{ESD} rating for NCV/SC devices is: Human Body Model – 2000 V; Machine Model – 200 V.

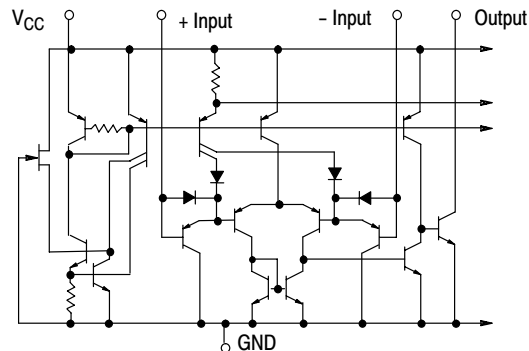

NOTE: Diagram shown is for 1 comparator.

Figure 1. Circuit Schematic

LM339, LM239, LM2901, LM2901V, NCV2901, MC3302

ELECTRICAL CHARACTERISTICS ($V_{CC} = +5.0$ Vdc, $T_A = +25^\circ\text{C}$, unless otherwise noted)

Characteristic	Symbol	LM239/339			LM2901/2901V/ NCV2901			MC3302			Unit
		Min	Typ	Max	Min	Typ	Max	Min	Typ	Max	
Input Offset Voltage (Note 4)	V_{IO}	–	± 2.0	± 5.0	–	± 2.0	± 7.0	–	± 3.0	± 20	mVdc
Input Bias Current (Notes 4, 5) (Output in Analog Range)	I_{IB}	–	25	250	–	25	250	–	25	500	nA
Input Offset Current (Note 4)	I_{IO}	–	± 5.0	± 50	–	± 5.0	± 50	–	± 3.0	± 100	nA
Input Common Mode Voltage Range	V_{ICMR}	0	–	$V_{CC} - 1.5$	0	–	$V_{CC} - 1.5$	0	–	$V_{CC} - 1.5$	V
Supply Current $R_L = \infty$ (For All Comparators) $R_L = \infty$, $V_{CC} = 30$ Vdc	I_{CC}	–	0.8 1.0	2.0 2.5	–	0.8 1.0	2.0 2.5	–	0.8 1.0	2.0 2.5	mA
Voltage Gain $R_L \geq 15$ k Ω , $V_{CC} = 15$ Vdc	A_{VOL}	50	200	–	25	100	–	25	100	–	V/mV
Large Signal Response Time $V_I =$ TTL Logic Swing, $V_{ref} = 1.4$ Vdc, $V_{RL} = 5.0$ Vdc, $R_L = 5.1$ k Ω	–	–	300	–	–	300	–	–	300	–	ns
Response Time (Note 6) $V_{RL} = 5.0$ Vdc, $R_L = 5.1$ k Ω	–	–	1.3	–	–	1.3	–	–	1.3	–	μs
Output Sink Current $V_I(-) \geq +1.0$ Vdc, $V_I(+)$ = 0, $V_O \leq 1.5$ Vdc	I_{Sink}	6.0	16	–	6.0	16	–	6.0	16	–	mA
Saturation Voltage $V_I(-) \geq +1.0$ Vdc, $V_I(+)$ = 0, $I_{sink} \leq 4.0$ mA	V_{sat}	–	130	400	–	130	400	–	130	500	mV
Output Leakage Current $V_I(+)$ $\geq +1.0$ Vdc, $V_I(-)$ = 0, $V_O = +5.0$ Vdc	I_{OL}	–	0.1	–	–	0.1	–	–	0.1	–	nA

3. (LM239) $T_{low} = -25^\circ\text{C}$, $T_{high} = +85^\circ\text{C}$
 (LM339) $T_{low} = 0^\circ\text{C}$, $T_{high} = +70^\circ\text{C}$
 (MC3302) $T_{low} = -40^\circ\text{C}$, $T_{high} = +85^\circ\text{C}$
 (LM2901) $T_{low} = -40^\circ\text{C}$, $T_{high} = +105^\circ\text{C}$
 (LM2901V & NCV2901) $T_{low} = -40^\circ\text{C}$, $T_{high} = +125^\circ\text{C}$
NCV2901 is qualified for automotive use.
4. At the output switch point, $V_O \approx 1.4$ Vdc, $R_S \leq 100 \Omega$, 5.0 Vdc $\leq V_{CC} \leq 30$ Vdc, with the inputs over the full common mode range (0 Vdc to $V_{CC} - 1.5$ Vdc).
5. The bias current flows out of the inputs due to the PNP input stage. This current is virtually constant, independent of the output state.
6. The response time specified is for a 100 mV input step with 5.0 mV overdrive. For larger signals, 300 ns is typical.

LM339, LM239, LM2901, LM2901V, NCV2901, MC3302

PERFORMANCE CHARACTERISTICS ($V_{CC} = +5.0$ Vdc, $T_A = T_{low}$ to T_{high} [Note 7])

Characteristic	Symbol	LM239/339			LM2901/2901V/ NCV2901			MC3302			Unit
		Min	Typ	Max	Min	Typ	Max	Min	Typ	Max	
Input Offset Voltage (Note 8)	V_{IO}	-	-	± 9.0	-	-	± 15	-	-	± 40	mVdc
Input Bias Current (Notes 8, 9) (Output in Analog Range)	I_{IB}	-	-	400	-	-	500	-	-	1000	nA
Input Offset Current (Note 8)	I_{IO}	-	-	± 150	-	-	± 200	-	-	± 300	nA
Input Common Mode Voltage Range	V_{ICMR}	0	-	$V_{CC} - 2.0$	0	-	$V_{CC} - 2.0$	0	-	$V_{CC} - 2.0$	V
Saturation Voltage $V_{I(-)} \geq +1.0$ Vdc, $V_{I(+)} = 0$, $I_{sink} \leq 4.0$ mA	V_{sat}	-	-	700	-	-	700	-	-	700	mV
Output Leakage Current $V_{I(+)} \geq +1.0$ Vdc, $V_{I(-)} = 0$, $V_O = 30$ Vdc	I_{OL}	-	-	1.0	-	-	1.0	-	-	1.0	μ A
Differential Input Voltage All $V_I \geq 0$ Vdc	V_{ID}	-	-	V_{CC}	-	-	V_{CC}	-	-	V_{CC}	Vdc

7. (LM239) $T_{low} = -25^\circ\text{C}$, $T_{high} = +85^\circ\text{C}$
 (LM339) $T_{low} = 0^\circ\text{C}$, $T_{high} = +70^\circ\text{C}$
 (MC3302) $T_{low} = -40^\circ\text{C}$, $T_{high} = +85^\circ\text{C}$
 (LM2901) $T_{low} = -40^\circ\text{C}$, $T_{high} = +105^\circ\text{C}$
 (LM2901V & NCV2901) $T_{low} = -40^\circ\text{C}$, $T_{high} = +125^\circ\text{C}$
NCV2901 is qualified for automotive use.
8. At the output switch point, $V_O \approx 1.4$ Vdc, $R_S \leq 100 \Omega$ 5.0 Vdc $\leq V_{CC} \leq 30$ Vdc, with the inputs over the full common mode range (0 Vdc to $V_{CC} - 1.5$ Vdc).
9. The bias current flows out of the inputs due to the PNP input stage. This current is virtually constant, independent of the output state.
10. The response time specified is for a 100 mV input step with 5.0 mV overdrive. For larger signals, 300 ns is typical.

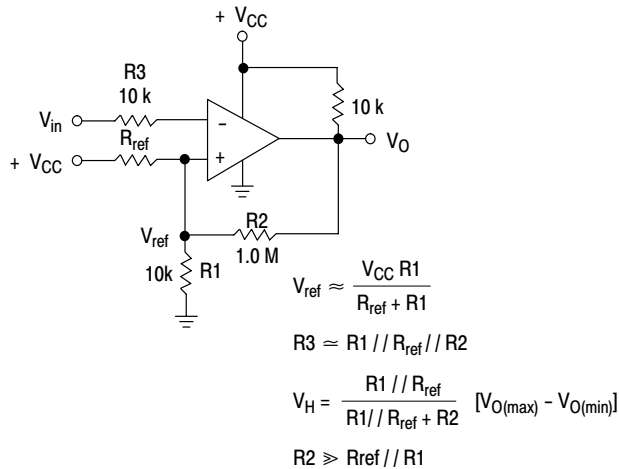

Figure 2. Inverting Comparator with Hysteresis

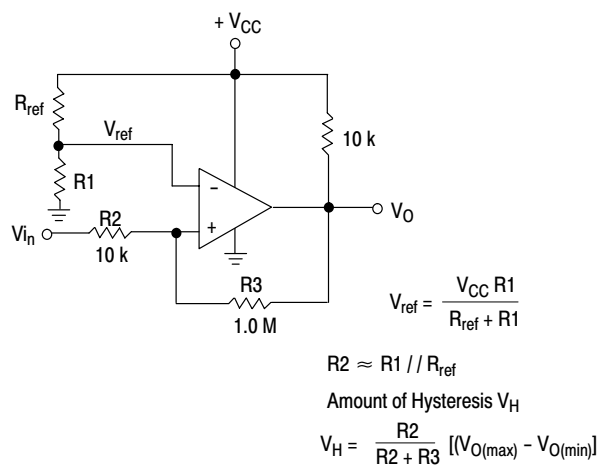

Figure 3. Noninverting Comparator with Hysteresis

LM339, LM239, LM2901, LM2901V, NCV2901, MC3302

ORDERING INFORMATION

Device	Package	Shipping [†]
LM339N	PDIP-14	25 Units/Rail
LM339NG	PDIP-14 (Pb-Free)	
LM2901D	SOIC-14	55 Units/Rail
LM2901DG	SOIC-14 (Pb-Free)	
LM2901DR2	SOIC-14	2500 / Tape & Reel
LM2901DR2G	SOIC-14 (Pb-Free)	
LM2901DTBR2	TSSOP-14*	
LM2901DTBR2G	TSSOP-14*	
LM2901N	PDIP-14	
LM2901NG	PDIP-14 (Pb-Free)	25 Units/Rail
LM2901VD	SOIC-14	55 Units/Tube
LM2901VDG	SOIC-14 (Pb-Free)	
LM2901VDR2	SOIC-14	2500 / Tape & Reel
LM2901VDR2G	SOIC-14 (Pb-Free)	
LM2901VDTBR2	TSSOP-14*	
LM2901VDTBR2G	TSSOP-14*	
LM2901VN	PDIP-14	
LM2901VNG	PDIP-14 (Pb-Free)	25 Units/Rail
NCV2901DR2	SOIC-14	2500 / Tape & Reel
NCV2901DR2G	SOIC-14 (Pb-Free)	
NCV2901DTBR2G	TSSOP-14*	
NCV2901CTR	Bare Die	6000 / Tape & Reel
MC3302D	SOIC-14	55 Units/Tube
MC3302DG	SOIC-14 (Pb-Free)	
MC3302DR2	SOIC-14	2500 / Tape & Reel
MC3302DR2G	SOIC-14 (Pb-Free)	
MC3302DTBR2	TSSOP-14*	
MC3302DTBR2G	TSSOP-14*	
MC3302P	PDIP-14	
MC3302PG	PDIP-14 (Pb-Free)	25 Units/Rail

[†]For information on tape and reel specifications, including part orientation and tape sizes, please refer to our Tape and Reel Packaging Specifications Brochure, BRD8011/D.

*This package is inherently Pb-Free.

PACKAGE DIMENSIONS

SOIC-14
CASE 751A-03
ISSUE H

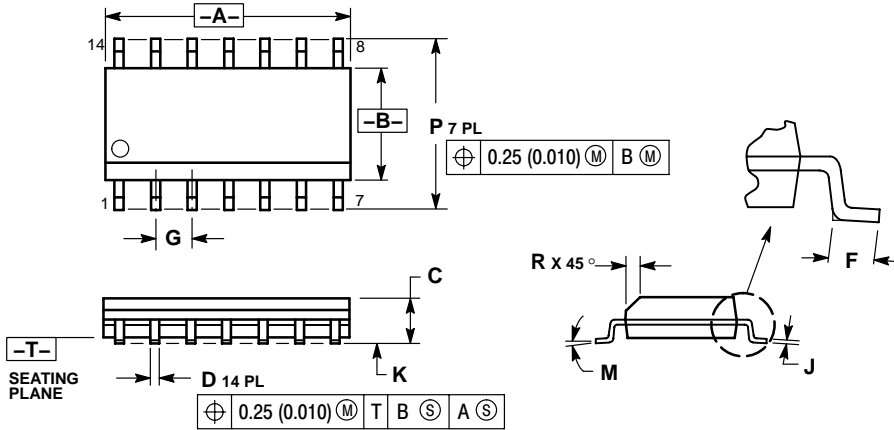

NOTES:

1. DIMENSIONING AND TOLERANCING PER ANSI Y14.5M, 1982.
2. CONTROLLING DIMENSION: MILLIMETER.
3. DIMENSIONS A AND B DO NOT INCLUDE MOLD PROTRUSION.
4. MAXIMUM MOLD PROTRUSION 0.15 (0.006) PER SIDE.
5. DIMENSION D DOES NOT INCLUDE DAMBAR PROTRUSION. ALLOWABLE DAMBAR PROTRUSION SHALL BE 0.127 (0.005) TOTAL IN EXCESS OF THE D DIMENSION AT MAXIMUM MATERIAL CONDITION.

DIM	MILLIMETERS		INCHES	
	MIN	MAX	MIN	MAX
A	8.55	8.75	0.337	0.344
B	3.80	4.00	0.150	0.157
C	1.35	1.75	0.054	0.068
D	0.35	0.49	0.014	0.019
F	0.40	1.25	0.016	0.049
G	1.27 BSC		0.050 BSC	
J	0.19	0.25	0.008	0.009
K	0.10	0.25	0.004	0.009
M	0°	7°	0°	7°
P	5.80	6.20	0.228	0.244
R	0.25	0.50	0.010	0.019

SOLDERING FOOTPRINT*

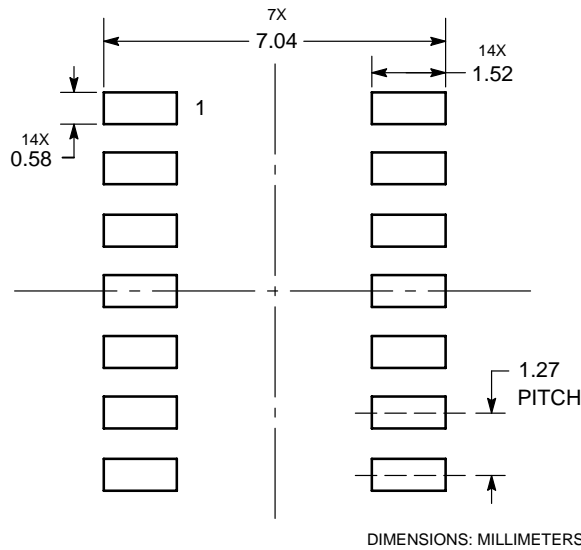

*For additional information on our Pb-Free strategy and soldering details, please download the ON Semiconductor Soldering and Mounting Techniques Reference Manual, SOLDERRM/D.