



DM74LS390 Dual 4-Bit Decade Counter

General Description

Each of these monolithic circuits contains eight master-slave flip-flops and additional gating to implement two individual four-bit counters in a single package. The 'LS390 incorporates dual divide-by-two and divide-by-five counters, which can be used to implement cycle lengths equal to any whole and/or cumulative multiples of 2 and/or 5 up to divide-by-100. When connected as a bi-quinary counter, the separate divide-by-two circuit can be used to provide symmetry (a square wave) at the final output stage. The 'LS390 has parallel outputs from each counter stage so that any submultiple of the input count frequency is available for system-timing signals.

Features

- Dual version of the popular 'LS90
- 'LS390 ... individual clocks for A and B flip-flops provide dual $\div 2$ and $\div 5$ counters
- Direct clear for each 4-bit counter
- Dual 4-bit version can significantly improve system densities by reducing counter package count by 50%
- Typical maximum count frequency ... 35 MHz
- Buffered outputs reduce possibility of collector commutation

Connection Diagram

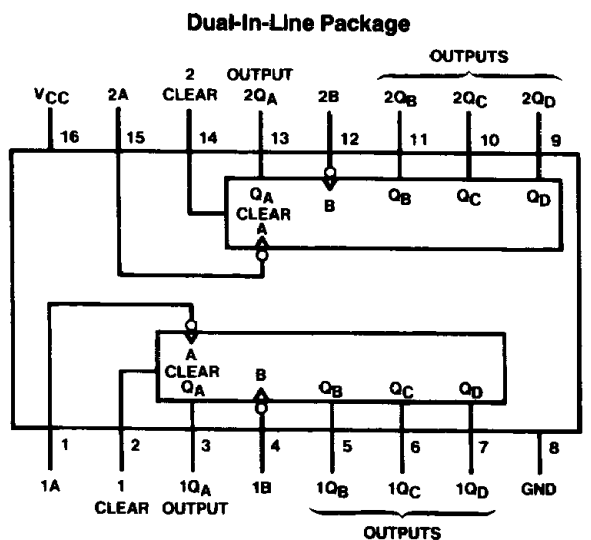

Order Number DM74LS390M or DM74LS390N
See NS Package Number M16A or N16E

Function Tables

**BCD Count Sequence
(Each Counter)
(See Note A)**

Count	Outputs			
	Q _D	Q _C	Q _B	Q _A
0	L	L	L	L
1	L	L	L	H
2	L	L	H	L
3	L	L	H	H
4	L	H	L	L
5	L	H	L	H
6	L	H	H	L
7	L	H	H	H
8	H	L	L	L
9	H	L	L	H

**Bi-Quinary (5-2)
(Each Counter)
(See Note B)**

Count	Outputs			
	Q _A	Q _D	Q _C	Q _B
0	L	L	L	L
1	L	L	L	H
2	L	L	H	L
3	L	L	H	H
4	L	H	L	L
5	H	L	L	L
6	H	L	L	H
7	H	L	H	L
8	H	L	H	H
9	H	H	L	L

Note A: Output Q_A is connected to input B for BCD count.

Note B: Output Q_D is connected to input A for Bi-quinary count.

Note C: H = High Level, L = Low Level.

Absolute Maximum Ratings (Note)

If Military/Aerospace specified devices are required, please contact the National Semiconductor Sales Office/Distributors for availability and specifications.

Supply Voltage	7V
Input Voltage	
Clear	7V
A or B	5.5V
Operating Free Air Temperature Range	
DM74LS	0°C to +70°C
Storage Temperature Range	-65°C to +150°C

Note: The "Absolute Maximum Ratings" are those values beyond which the safety of the device cannot be guaranteed. The device should not be operated at these limits. The parametric values defined in the "Electrical Characteristics" table are not guaranteed at the absolute maximum ratings. The "Recommended Operating Conditions" table will define the conditions for actual device operation.

Recommended Operating Conditions

Symbol	Parameter		DM74LS390			Units
			Min	Nom	Max	
V _{CC}	Supply Voltage		4.75	5	5.25	V
V _{IH}	High Level Input Voltage		2			V
V _{IL}	Low Level Input Voltage				0.8	V
I _{OH}	High Level Output Current				-0.4	mA
I _{OL}	Low Level Output Current				8	mA
f _{CLK}	Clock Frequency (Note 1)	A to Q _A	0		25	MHz
		B to Q _B	0		20	
f _{CLK}	Clock Frequency (Note 2)	A to Q _A	0		20	MHz
		B to Q _B	0		15	
t _w	Pulse Width (Note 1)	A	20			ns
		B	25			
		Clear High	20			
t _{REL}	Clear Release Time (Notes 3 & 4)		25 ↓			ns
T _A	Free Air Operating Temperature		0		70	°C

Note 1: C_L = 15 pF, R_L = 2 kΩ, T_A = 25°C and V_{CC} = 5V.

Note 2: C_L = 50 pF, R_L = 2 kΩ, T_A = 25°C and V_{CC} = 5V.

Note 3: The symbol (↓) indicates the falling edge of the clear pulse is used for reference.

Note 4: T_A = 25°C and V_{CC} = 5V.

Electrical Characteristics over recommended operating free air temperature range (unless otherwise noted)

Symbol	Parameter	Conditions	Min	Typ (Note 1)	Max	Units
V _I	Input Clamp Voltage	V _{CC} = Min, I _I = -18 mA			-1.5	V
V _{OH}	High Level Output Voltage	V _{CC} = Min, I _{OH} = Max V _{IL} = Max, V _{IH} = Min	2.7	3.4		V
V _{OL}	Low Level Output Voltage	V _{CC} = Min, I _{OL} = Max V _{IL} = Max, V _{IH} = Min		0.35	0.5	V
		I _{OL} = 4 mA, V _{CC} = Min		0.25	0.4	
I _I	Input Current @ Max Input Voltage	V _{CC} = Max, V _I = 7V	Clear		0.1	mA
		V _{CC} = Max V _I = 5.5V	A		0.2	
			B		0.4	
I _{IH}	High Level Input Current	V _{CC} = Max V _I = 2.7V	Clear		20	μA
			A		40	
			B		80	

Electrical Characteristics

over recommended operating free air temperature range (unless otherwise noted) (Continued)

Symbol	Parameter	Conditions	Min	Typ (Note 1)	Max	Units
I_{IL}	Low Level Input Current	$V_{CC} = \text{Max}, V_I = 0.4V$	Clear		-0.4	mA
			A		-1.6	
			B		-2.4	
I_{OS}	Short Circuit Output Current	$V_{CC} = \text{Max}$ (Note 2)	DM74	-20	-100	mA
I_{CC}	Supply Current	$V_{CC} = \text{Max}$ (Note 3)		15	26	mA

Note 1: All typicals are at $V_{CC} = 5V, T_A = 25^\circ C$.**Note 2:** Not more than one output should be shorted at a time, and the duration should not exceed one second.**Note 3:** I_{CC} is measured with all outputs open, both CLEAR inputs grounded following momentary connection to 4.5 and all other inputs grounded.**Switching Characteristics** at $V_{CC} = 5V$ and $T_A = 25^\circ C$ (See Section 1 for Test Waveforms and Output Load)

Symbol	Parameter	From (Input) To (Output)	$R_L = 2 k\Omega$				Units
			$C_L = 15 pF$		$C_L = 50 pF$		
			Min	Max	Min	Max	
f_{MAX}	Maximum Clock Frequency	A to Q_A	25		20		MHz
		B to Q_B	20		15		
t_{PLH}	Propagation Delay Time Low to High Level Output	A to Q_A		20		24	ns
t_{PHL}	Propagation Delay Time High to Low Level Output	A to Q_A		20		30	ns
t_{PLH}	Propagation Delay Time Low to High Level Output	A to Q_C		60		81	ns
t_{PHL}	Propagation Delay Time High to Low Level Output	A to Q_C		60		81	ns
t_{PLH}	Propagation Delay Time Low to High Level Output	B to Q_B		21		27	ns
t_{PHL}	Propagation Delay Time High to Low Level Output	B to Q_B		21		33	ns
t_{PLH}	Propagation Delay Time Low to High Level Output	B to Q_C		39		51	ns
t_{PHL}	Propagation Delay Time High to Low Level Output	B to Q_C		39		54	ns
t_{PLH}	Propagation Delay Time Low to High Level Output	B to Q_D		21		27	ns
t_{PHL}	Propagation Delay Time High to Low Level Output	B to Q_D		21		33	ns
t_{PHL}	Propagation Delay Time High to Low Level Output	Clear to Any Q		39		45	ns

Logic Diagram

'LS390

LS390

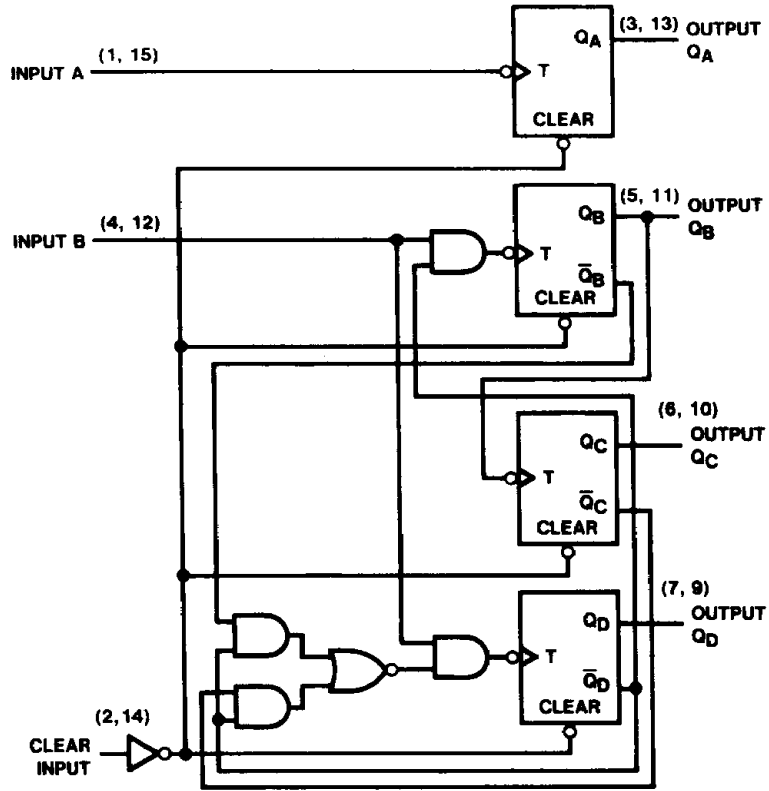

TL/F/6433-2

This datasheet has been downloaded from:

www.DatasheetCatalog.com

Datasheets for electronic components.

National Semiconductor was acquired by Texas Instruments.

http://www.ti.com/corp/docs/investor_relations/pr_09_23_2011_national_semiconductor.html

This file is the datasheet for the following electronic components:

DM74LS390M - <http://www.ti.com/product/dm74ls390m?HQS=TI-null-null-dscatalog-df-pf-null-wwe>

DM74LS390N - <http://www.ti.com/product/dm74ls390n?HQS=TI-null-null-dscatalog-df-pf-null-wwe>