

# TL431C, TL431AC, TL431I, TL431AI, TL431M, TL431Y ADJUSTABLE PRECISION SHUNT REGULATORS

SLVS0051 – JULY 1978 – REVISED AUGUST 1998

- Equivalent Full-Range Temperature Coefficient . . . 30 ppm/°C
- 0.2-Ω Typical Output Impedance
- Sink-Current Capability . . . 1 mA to 100 mA
- Low Output Noise
- Adjustable Output Voltage . . .  $V_{ref}$  to 36 V
- Available in a Wide Range of High-Density Packages

## description

The TL431 and TL431A are 3-terminal adjustable shunt regulators with specified thermal stability over applicable automotive, commercial, and military temperature ranges. The output voltage can be set to any value between  $V_{ref}$  (approximately 2.5 V) and 36 V with two external resistors (see Figure 17). These devices have a typical output impedance of 0.2 Ω. Active output circuitry provides a very sharp turn-on characteristic, making these devices excellent replacements for Zener diodes in many applications, such as on-board regulation, adjustable power supplies, and switching power supplies.

The TL431C and TL431AC are characterized for operation from 0°C to 70°C, and the TL431I and TL431AI are characterized for operation from -40°C to 85°C. The TL431M is characterized for operation over the full military temperature range of -55°C to 125°C.

**D PACKAGE  
(TOP VIEW)**

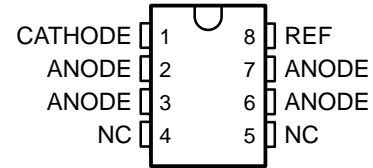

**JG, P, OR PW PACKAGE  
(TOP VIEW)**

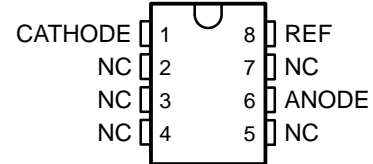

**PK PACKAGE  
(TOP VIEW)**

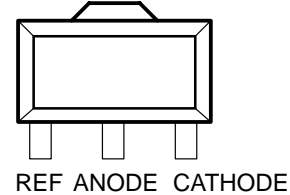

**LP PACKAGE  
(TOP VIEW)**

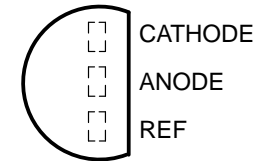

**FK PACKAGE  
(TOP VIEW)**

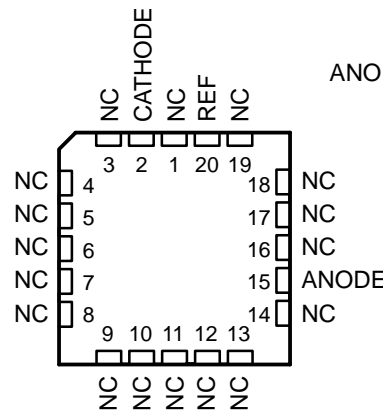

NC – No internal connection

**KTP PACKAGE  
(TOP VIEW)**

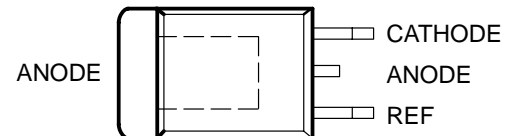

Please be aware that an important notice concerning availability, standard warranty, and use in critical applications of Texas Instruments semiconductor products and disclaimers thereto appears at the end of this data sheet.

PRODUCTION DATA information is current as of publication date. Products conform to specifications per the terms of Texas Instruments standard warranty. Production processing does not necessarily include testing of all parameters.

**TEXAS  
INSTRUMENTS**

POST OFFICE BOX 655303 • DALLAS, TEXAS 75265

Copyright © 1998, Texas Instruments Incorporated  
On products compliant to MIL-PRF-38535, all parameters are tested unless otherwise noted. On all other products, production processing does not necessarily include testing of all parameters.

# TL431C, TL431AC, TL431I, TL431AI, TL431M, TL431Y ADJUSTABLE PRECISION SHUNT REGULATORS

SLVS005I – JULY 1978 – REVISED AUGUST 1998

## AVAILABLE OPTIONS

T <sub>A</sub>	PACKAGED DEVICES								CHIP FORM (Y)
	SMALL OUTLINE (D)	CHIP CARRIER (FK)	CERAMIC DIP (JG)	PLASTIC FLANGE MOUNT (KTP)	TO-226AA (LP)	PLASTIC DIP (P)	SOT-89 (PK)	SHRINK SMALL OUTLINE (PW)	
0°C to 70°C	TL431CD TL431ACD			TL431CKTPR	TL431CLP TL431ACL P	TL431CP TL431ACP	TL431CPK	TL431CPW	TL431Y
-40°C to 85°C	TL431ID TL431AID				TL431ILP TL431AILP	TL431IP TL431AIP	TL431IPK		
-55°C to 125°C		TL431MFK	TL431MJG						

The D and LP packages are available taped and reeled. Add R suffix to device type (e.g., TL431CDR). The KTP and PK packages are only available taped and reeled. Chip forms are tested at T<sub>A</sub> = 25°C.

## symbol

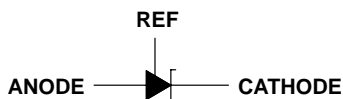

## functional block diagram

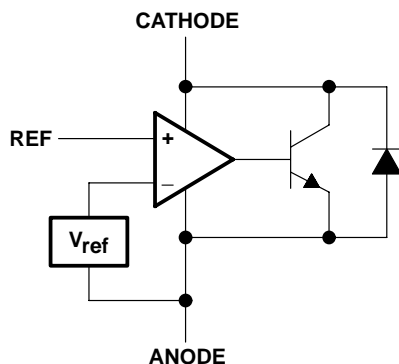

# TL431C, TL431AC, TL431I, TL431AI, TL431M, TL431Y ADJUSTABLE PRECISION SHUNT REGULATORS

SLVS005I – JULY 1978 – REVISED AUGUST 1998

## equivalent schematic†

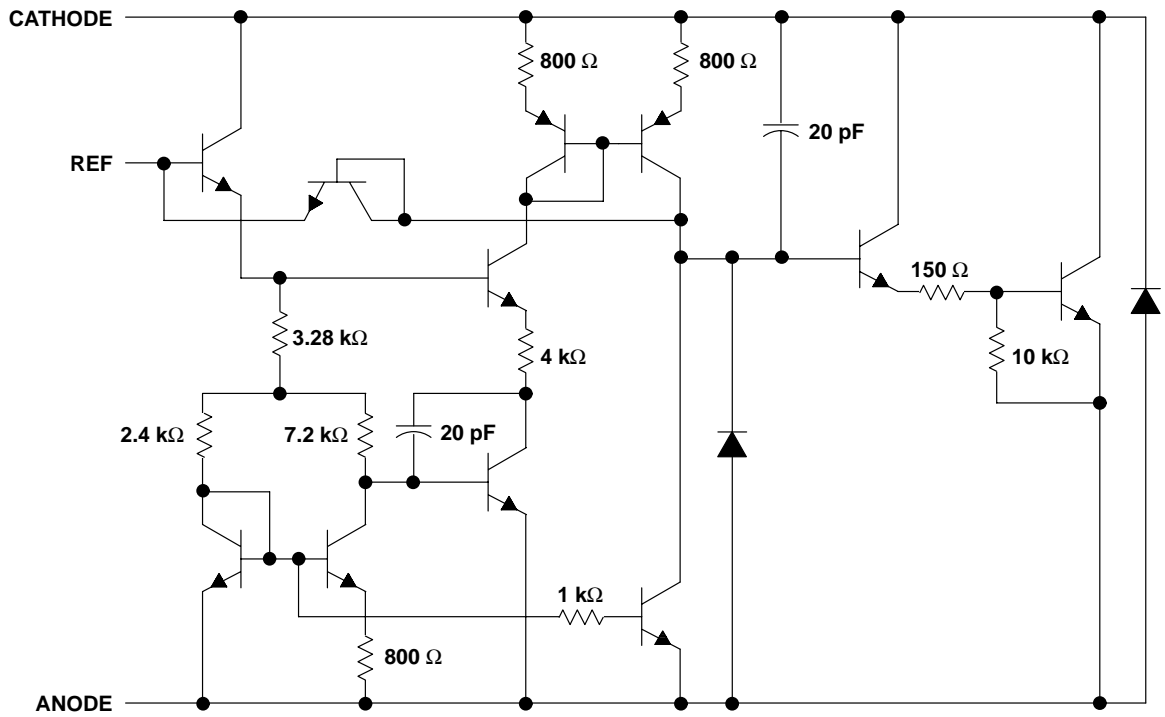

† All component values are nominal.

# TL431C, TL431AC, TL431I, TL431AI, TL431M, TL431Y ADJUSTABLE PRECISION SHUNT REGULATORS

SLVS005I – JULY 1978 – REVISED AUGUST 1998

## TL431Y chip information

This chip, when properly assembled, displays characteristics similar to those of the TL431C. Thermal compression or ultrasonic bonding can be used on the doped-aluminum bonding pads. The chip can be mounted with conductive epoxy or a gold-silicon preform.

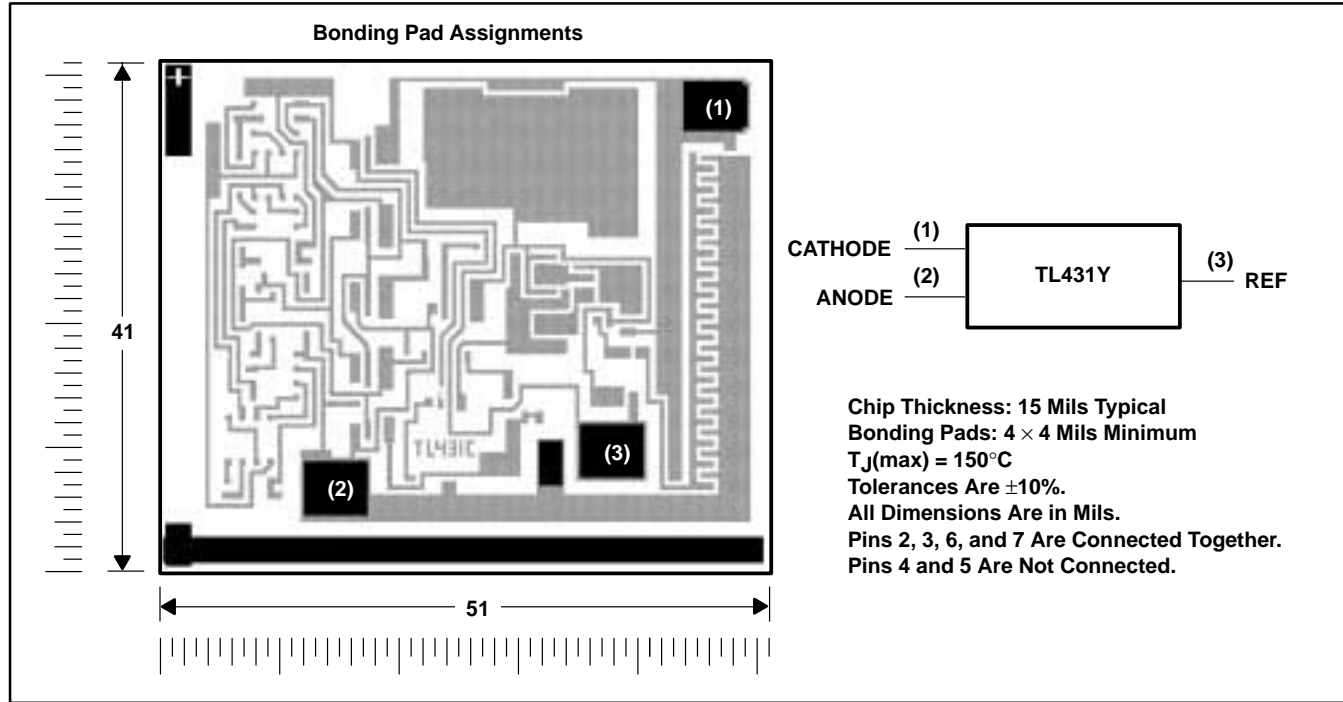

### absolute maximum ratings over operating free-air temperature range (unless otherwise noted)†

Cathode voltage, $V_{KA}$ (see Note 1)	37 V
Continuous cathode current range, $I_{KA}$	-100 mA to 150 mA
Reference input current range	-50 $\mu$ A to 10 mA
Continuous total power dissipation	See Dissipation Rating Tables 1 and 2
Storage temperature range, $T_{stg}$	-65°C to 150°C
Case temperature for 60 seconds: FK package	260°C
Lead temperature 1,6 mm (1/16 inch) from case for 10 seconds: D, P, or PW package	260°C
Lead temperature 1,6 mm (1/16 inch) from case for 60 seconds: JG, LP, or PK package	300°C

† Stresses beyond those listed under "absolute maximum ratings" may cause permanent damage to the device. These are stress ratings only, and functional operation of the device at these or any other conditions beyond those indicated under "recommended operating conditions" is not implied. Exposure to absolute-maximum-rated conditions for extended periods may affect device reliability.

NOTE 1: Voltage values are with respect to the anode terminal unless otherwise noted.

# TL431C, TL431AC, TL431I, TL431AI, TL431M, TL431Y ADJUSTABLE PRECISION SHUNT REGULATORS

SLVS005I – JULY 1978 – REVISED AUGUST 1998

**DISSIPATION RATING TABLE 1 – FREE-AIR TEMPERATURE**

PACKAGE	$T_A = 25^\circ\text{C}$ POWER RATING	DERATING FACTOR ABOVE $T_A = 25^\circ\text{C}$	$T_A = 70^\circ\text{C}$ POWER RATING	$T_A = 85^\circ\text{C}$ POWER RATING	$T_A = 125^\circ\text{C}$ POWER RATING
D	725 mW	5.8 mW/°C	464 mW	377 mW	—
FK	1375 mW	11 mW/°C	880 mW	715 mW	275 mW
JG	1050 mW	8.4 mW/°C	672 mW	546 mW	210 mW
KTP	1800 mW	14.5 mW/°C	1147 mW	943 mW	—
LP	775 mW	6.2 mW/°C	496 mW	403 mW	—
P	1000 mW	8 mW/°C	640 mW	520 mW	—
PK	500 mW	4 mW/°C	320 mW	260 mW	—
PW	525 mW	4.2 mW/°C	336 mW	—	—

**DISSIPATION RATING TABLE 2 – CASE TEMPERATURE**

PACKAGE	$T_C = 25^\circ\text{C}$ POWER RATING	DERATING FACTOR ABOVE $T_C = 25^\circ\text{C}$	$T_C = 70^\circ\text{C}$ POWER RATING	$T_C = 85^\circ\text{C}$ POWER RATING
PK	3125 mW	25 mW/°C	2000 mW	1625 mW

### recommended operating conditions

	MIN	MAX	UNIT
Cathode voltage, $V_{KA}$	$V_{ref}$	36	V
Cathode current, $I_{KA}$	1	100	mA
Operating free-air temperature range, $T_A$	C suffix	0	70
	I suffix	-40	85
	M suffix	-55	125
			°C



# TL431C, TL431AC, TL431I, TL431AI, TL431M, TL431Y ADJUSTABLE PRECISION SHUNT REGULATORS

SLVS005I – JULY 1978 – REVISED AUGUST 1998

electrical characteristics over recommended operating conditions,  $T_A = 25^\circ\text{C}$  (unless otherwise noted)

PARAMETER	TEST CIRCUIT	TEST CONDITIONS	TL431C			UNIT
			MIN	TYP	MAX	
$V_{\text{ref}}$ Reference voltage	2	$V_{\text{KA}} = V_{\text{ref}}, I_{\text{KA}} = 10 \text{ mA}$	2440	2495	2550	mV
$V_{\text{I(dev)}}$ Deviation of reference voltage over full temperature range (see Figure 1)	2	$V_{\text{KA}} = V_{\text{ref}}, I_{\text{KA}} = 10 \text{ mA}, T_A = \text{Full range}^\dagger$		4	25	mV
$\frac{\Delta V_{\text{ref}}}{\Delta V_{\text{KA}}}$ Ratio of change in reference voltage to the change in cathode voltage	3	$I_{\text{KA}} = 10 \text{ mA}$	$\Delta V_{\text{KA}} = 10 \text{ V} - V_{\text{ref}}$	-1.4	-2.7	$\frac{\text{mV}}{\text{V}}$
			$\Delta V_{\text{KA}} = 36 \text{ V} - 10 \text{ V}$	-1	-2	
$I_{\text{ref}}$ Reference current	3	$I_{\text{KA}} = 10 \text{ mA}, R1 = 10 \text{ k}\Omega, R2 = \infty$		2	4	$\mu\text{A}$
$I_{\text{I(dev)}}$ Deviation of reference current over full temperature range (see Figure 1)	3	$I_{\text{KA}} = 10 \text{ mA}, R1 = 10 \text{ k}\Omega, R2 = \infty, T_A = \text{Full range}^\dagger$		0.4	1.2	$\mu\text{A}$
$I_{\text{min}}$ Minimum cathode current for regulation	2	$V_{\text{KA}} = V_{\text{ref}}$		0.4	1	mA
$I_{\text{off}}$ Off-state cathode current	4	$V_{\text{KA}} = 36 \text{ V}, V_{\text{ref}} = 0$		0.1	1	$\mu\text{A}$
$ z_{\text{KA}} $ Dynamic impedance (see Figure 1)	1	$I_{\text{KA}} = 1 \text{ mA to } 100 \text{ mA}, V_{\text{KA}} = V_{\text{ref}}, f \leq 1 \text{ kHz}$		0.2	0.5	$\Omega$

$^\dagger$  Full temperature range is  $0^\circ\text{C}$  to  $70^\circ\text{C}$  for the TL431C.

The deviation parameters  $V_{\text{ref(dev)}}$  and  $I_{\text{ref(dev)}}$  are defined as the differences between the maximum and minimum values obtained over the recommended temperature range. The average full-range temperature coefficient of the reference voltage,  $\alpha_{V_{\text{ref}}}$ , is defined as:

$$|\alpha_{V_{\text{ref}}}| \left( \frac{\text{ppm}}{^\circ\text{C}} \right) = \frac{\left( \frac{V_{\text{I(dev)}}}{V_{\text{ref at } 25^\circ\text{C}}} \right) \times 10^6}{\Delta T_A}$$

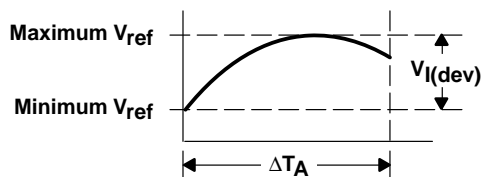

where:

$\Delta T_A$  is the recommended operating free-air temperature range of the device.

$\alpha_{V_{\text{ref}}}$  can be positive or negative, depending on whether minimum  $V_{\text{ref}}$  or maximum  $V_{\text{ref}}$ , respectively, occurs at the lower temperature.

Example: maximum  $V_{\text{ref}} = 2496 \text{ mV}$  at  $30^\circ\text{C}$ , minimum  $V_{\text{ref}} = 2492 \text{ mV}$  at  $0^\circ\text{C}$ ,  $V_{\text{ref}} = 2495 \text{ mV}$  at  $25^\circ\text{C}$ ,  $\Delta T_A = 70^\circ\text{C}$  for TL431C

$$|\alpha_{V_{\text{ref}}}| = \frac{\left( \frac{4 \text{ mV}}{2495 \text{ mV}} \right) \times 10^6}{70^\circ\text{C}} \approx 23 \text{ ppm}/^\circ\text{C}$$

Because minimum  $V_{\text{ref}}$  occurs at the lower temperature, the coefficient is positive.

### Calculating Dynamic Impedance

The dynamic impedance is defined as:  $|z_{\text{KA}}| = \frac{\Delta V_{\text{KA}}}{\Delta I_{\text{KA}}}$

When the device is operating with two external resistors (see Figure 3), the total dynamic impedance of the circuit is given by:

$$|z'| = \frac{\Delta V}{\Delta I} \approx |z_{\text{KA}}| \left( 1 + \frac{R1}{R2} \right)$$

Figure 1. Calculating Deviation Parameters and Dynamic Impedance

# TL431C, TL431AC, TL431I, TL431AI, TL431M, TL431Y ADJUSTABLE PRECISION SHUNT REGULATORS

SLVS005I – JULY 1978 – REVISED AUGUST 1998

**electrical characteristics over recommended operating conditions,  $T_A = 25^\circ\text{C}$  (unless otherwise noted)**

PARAMETER	TEST CIRCUIT	TEST CONDITIONS	TL431I			UNIT
			MIN	TYP	MAX	
$V_{\text{ref}}$ Reference voltage	2	$V_{\text{KA}} = V_{\text{ref}}, I_{\text{KA}} = 10 \text{ mA}$	2440	2495	2550	mV
$V_{\text{I(dev)}}$ Deviation of reference voltage over full temperature range (see Figure 1)	2	$V_{\text{KA}} = V_{\text{ref}}, I_{\text{KA}} = 10 \text{ mA}, T_A = \text{Full range}^\dagger$		5	50	mV
$\frac{\Delta V_{\text{ref}}}{\Delta V_{\text{KA}}}$ Ratio of change in reference voltage to the change in cathode voltage	3	$I_{\text{KA}} = 10 \text{ mA}$	$\Delta V_{\text{KA}} = 10 \text{ V} - V_{\text{ref}}$	-1.4	-2.7	$\frac{\text{mV}}{\text{V}}$
			$\Delta V_{\text{KA}} = 36 \text{ V} - 10 \text{ V}$	-1	-2	
$I_{\text{ref}}$ Reference current	3	$I_{\text{KA}} = 10 \text{ mA}, R1 = 10 \text{ k}\Omega, R2 = \infty$		2	4	$\mu\text{A}$
$I_{\text{I(dev)}}$ Deviation of reference current over full temperature range (see Figure 1)	3	$I_{\text{KA}} = 10 \text{ mA}, R1 = 10 \text{ k}\Omega, R2 = \infty, T_A = \text{Full range}^\dagger$		0.8	2.5	$\mu\text{A}$
$I_{\text{min}}$ Minimum cathode current for regulation	2	$V_{\text{KA}} = V_{\text{ref}}$		0.4	1	mA
$I_{\text{off}}$ Off-state cathode current	4	$V_{\text{KA}} = 36 \text{ V}, V_{\text{ref}} = 0$		0.1	1	$\mu\text{A}$
$ z_{\text{KA}} $ Dynamic impedance (see Figure 1)	2	$I_{\text{KA}} = 1 \text{ mA to } 100 \text{ mA}, V_{\text{KA}} = V_{\text{ref}}, f \leq 1 \text{ kHz}$		0.2	0.5	$\Omega$

<sup>†</sup> Full temperature range is  $-40^\circ\text{C}$  to  $85^\circ\text{C}$  for the TL431I.

**electrical characteristics over recommended operating conditions,  $T_A = 25^\circ\text{C}$  (unless otherwise noted)**

PARAMETER	TEST CIRCUIT	TEST CONDITIONS	TL431M			UNIT
			MIN	TYP	MAX	
$V_{\text{ref}}$ Reference voltage	2	$V_{\text{KA}} = V_{\text{ref}}, I_{\text{KA}} = 10 \text{ mA}$	2400	2495	2600	mV
$V_{\text{I(dev)}}$ Deviation of reference voltage over full temperature range (see Figure 1)	2	$V_{\text{KA}} = V_{\text{ref}}, I_{\text{KA}} = 10 \text{ mA}, T_A = \text{Full range}^\ddagger$		22		mV
$\frac{\Delta V_{\text{ref}}}{\Delta V_{\text{KA}}}$ Ratio of change in reference voltage to the change in cathode voltage	3	$I_{\text{KA}} = 10 \text{ mA}$	$\Delta V_{\text{KA}} = 10 \text{ V} - V_{\text{ref}}$	-1.4	-3	$\frac{\text{mV}}{\text{V}}$
			$\Delta V_{\text{KA}} = 36 \text{ V} - 10 \text{ V}$	-1	-2.3	
$I_{\text{ref}}$ Reference current	3	$I_{\text{KA}} = 10 \text{ mA}, R1 = 10 \text{ k}\Omega, R2 = \infty$		2	8*	$\mu\text{A}$
$I_{\text{I(dev)}}$ Deviation of reference current over full temperature range (see Figure 1)	3	$I_{\text{KA}} = 10 \text{ mA}, R1 = 10 \text{ k}\Omega, R2 = \infty, T_A = \text{Full range}^\ddagger$		1		$\mu\text{A}$
$I_{\text{min}}$ Minimum cathode current for regulation	2	$V_{\text{KA}} = V_{\text{ref}}$		0.4	1.5	mA
$I_{\text{off}}$ Off-state cathode current	4	$V_{\text{KA}} = 36 \text{ V}, V_{\text{ref}} = 0$		0.1	3	$\mu\text{A}$
$ z_{\text{KA}} $ Dynamic impedance (see Figure 1)	1	$I_{\text{KA}} = 1 \text{ mA to } 100 \text{ mA}, V_{\text{KA}} = V_{\text{ref}}, f \leq 1 \text{ kHz}$		0.2	0.9*	$\Omega$

\* On products compliant to MIL-PRF-38535, this parameter is not production tested.

<sup>‡</sup> Full temperature range is  $-55^\circ\text{C}$  to  $125^\circ\text{C}$  for the TL431M.



# TL431C, TL431AC, TL431I, TL431AI, TL431M, TL431Y ADJUSTABLE PRECISION SHUNT REGULATORS

SLVS005I – JULY 1978 – REVISED AUGUST 1998

**electrical characteristics over recommended operating conditions,  $T_A = 25^\circ\text{C}$  (unless otherwise noted)**

PARAMETER	TEST CIRCUIT	TEST CONDITIONS	TL431AC			UNIT
			MIN	TYP	MAX	
$V_{\text{ref}}$ Reference voltage	2	$V_{\text{KA}} = V_{\text{ref}}, I_{\text{KA}} = 10 \text{ mA}$	2470	2495	2520	mV
$V_{\text{I(dev)}}$ Deviation of reference voltage over full temperature range (see Figure 1)	2	$V_{\text{KA}} = V_{\text{ref}}, I_{\text{KA}} = 10 \text{ mA}, T_A = \text{Full range}^\dagger$		4	25	mV
$\frac{\Delta V_{\text{ref}}}{\Delta V_{\text{KA}}}$ Ratio of change in reference voltage to the change in cathode voltage	3	$I_{\text{KA}} = 10 \text{ mA}$	$\Delta V_{\text{KA}} = 10 \text{ V} - V_{\text{ref}}$	-1.4	-2.7	$\frac{\text{mV}}{\text{V}}$
			$\Delta V_{\text{KA}} = 36 \text{ V} - 10 \text{ V}$	-1	-2	
$I_{\text{ref}}$ Reference current	3	$I_{\text{KA}} = 10 \text{ mA}, R1 = 10 \text{ k}\Omega, R2 = \infty$		2	4	$\mu\text{A}$
$I_{\text{I(dev)}}$ Deviation of reference current over full temperature range (see Figure 1)	3	$I_{\text{KA}} = 10 \text{ mA}, R1 = 10 \text{ k}\Omega, R2 = \infty, T_A = \text{Full range}^\dagger$		0.8	1.2	$\mu\text{A}$
$I_{\text{min}}$ Minimum cathode current for regulation	2	$V_{\text{KA}} = V_{\text{ref}}$		0.4	0.6	mA
$I_{\text{off}}$ Off-state cathode current	4	$V_{\text{KA}} = 36 \text{ V}, V_{\text{ref}} = 0$		0.1	0.5	$\mu\text{A}$
$ z_{\text{KA}} $ Dynamic impedance (see Figure 1)	1	$I_{\text{KA}} = 1 \text{ mA to } 100 \text{ mA}, V_{\text{KA}} = V_{\text{ref}}, f \leq 1 \text{ kHz}$		0.2	0.5	$\Omega$

<sup>†</sup> Full temperature range is  $0^\circ\text{C}$  to  $70^\circ\text{C}$  for the TL431AC.

**electrical characteristics over recommended operating conditions,  $T_A = 25^\circ\text{C}$  (unless otherwise noted)**

PARAMETER	TEST CIRCUIT	TEST CONDITIONS	TL431AI			UNIT
			MIN	TYP	MAX	
$V_{\text{ref}}$ Reference voltage	2	$V_{\text{KA}} = V_{\text{ref}}, I_{\text{KA}} = 10 \text{ mA}$	2470	2495	2520	mV
$V_{\text{I(dev)}}$ Deviation of reference voltage over full temperature range (see Figure 1)	2	$V_{\text{KA}} = V_{\text{ref}}, I_{\text{KA}} = 10 \text{ mA}, T_A = \text{Full range}^\ddagger$		5	50	mV
$\frac{\Delta V_{\text{ref}}}{\Delta V_{\text{KA}}}$ Ratio of change in reference voltage to the change in cathode voltage	3	$I_{\text{KA}} = 10 \text{ mA}$	$\Delta V_{\text{KA}} = 10 \text{ V} - V_{\text{ref}}$	-1.4	-2.7	$\frac{\text{mV}}{\text{V}}$
			$\Delta V_{\text{KA}} = 36 \text{ V} - 10 \text{ V}$	-1	-2	
$I_{\text{ref}}$ Reference current	3	$I_{\text{KA}} = 10 \text{ mA}, R1 = 10 \text{ k}\Omega, R2 = \infty$		2	4	$\mu\text{A}$
$I_{\text{I(dev)}}$ Deviation of reference current over full temperature range (see Figure 1)	3	$I_{\text{KA}} = 10 \text{ mA}, R1 = 10 \text{ k}\Omega, R2 = \infty, T_A = \text{Full range}^\ddagger$		0.8	2.5	$\mu\text{A}$
$I_{\text{min}}$ Minimum cathode current for regulation	2	$V_{\text{KA}} = V_{\text{ref}}$		0.4	0.7	mA
$I_{\text{off}}$ Off-state cathode current	4	$V_{\text{KA}} = 36 \text{ V}, V_{\text{ref}} = 0$		0.1	0.5	$\mu\text{A}$
$ z_{\text{KA}} $ Dynamic impedance (see Figure 1)	2	$I_{\text{KA}} = 1 \text{ mA to } 100 \text{ mA}, V_{\text{KA}} = V_{\text{ref}}, f \leq 1 \text{ kHz}$		0.2	0.5	$\Omega$

<sup>‡</sup> Full temperature range is  $-40^\circ\text{C}$  to  $85^\circ\text{C}$  for the TL431AI.





electrical characteristics over recommended operating conditions,  $T_A = 25^\circ\text{C}$  (unless otherwise noted)

PARAMETER	TEST CIRCUIT	TEST CONDITIONS	TL431Y			UNIT
			MIN	TYP	MAX	
$V_{\text{ref}}$	Reference voltage	2	$V_{\text{KA}} = V_{\text{ref}}$	$I_{\text{KA}} = 10 \text{ mA}$	2495	mV
$\frac{\Delta V_{\text{ref}}}{\Delta V_{\text{KA}}}$	Ratio of change in reference voltage to the change in cathode voltage	3	$I_{\text{KA}} = 10 \text{ mA}$	$\Delta V_{\text{KA}} = 10 \text{ V} - V_{\text{ref}}$	-1.4	$\frac{\text{mV}}{\text{V}}$
				$\Delta V_{\text{KA}} = 36 \text{ V} - 10 \text{ V}$	-1	
$I_{\text{ref}}$	Reference input current	3	$I_{\text{KA}} = 10 \text{ mA}$ , $R_1 = 10 \text{ k}\Omega$ , $R_2 = \infty$		2	$\mu\text{A}$
$I_{\text{min}}$	Minimum cathode current for regulation	2	$V_{\text{KA}} = V_{\text{ref}}$		0.4	mA
$I_{\text{off}}$	Off-state cathode current	4	$V_{\text{KA}} = 36 \text{ V}$ , $V_{\text{ref}} = 0$		0.1	$\mu\text{A}$
$ z_{\text{KA}} $	Dynamic impedance†	2	$I_{\text{KA}} = 1 \text{ mA to } 100 \text{ mA}$ , $V_{\text{KA}} = V_{\text{ref}}$ , $f \leq 1 \text{ kHz}$		0.2	$\Omega$

† Calculating dynamic impedance:

The dynamic impedance is defined as:  $|z_{\text{KA}}| = \frac{\Delta V_{\text{KA}}}{\Delta I_{\text{KA}}}$

When the device is operating with two external resistors (see Figure 3), the total dynamic impedance of the circuit is given by:

$$|z'| = \frac{\Delta V}{\Delta I} \approx |z_{\text{KA}}| \left( 1 + \frac{R_1}{R_2} \right)$$

### PARAMETER MEASUREMENT INFORMATION

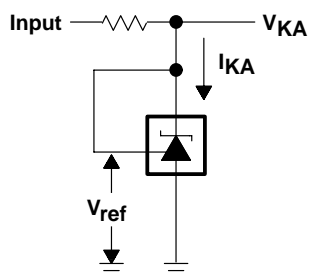

Figure 2. Test Circuit for  $V_{\text{KA}} = V_{\text{ref}}$

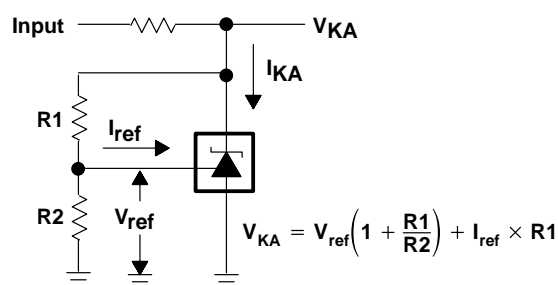

Figure 3. Test Circuit for  $V_{\text{KA}} > V_{\text{ref}}$

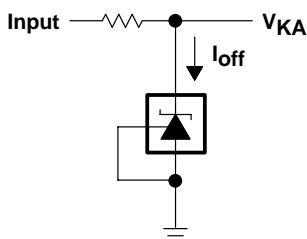

Figure 4. Test Circuit for  $I_{\text{off}}$

# TL431C, TL431AC, TL431I, TL431AI, TL431M, TL431Y ADJUSTABLE PRECISION SHUNT REGULATORS

SLVS005I – JULY 1978 – REVISED AUGUST 1998

---

## TYPICAL CHARACTERISTICS

Table 1. Graphs

	FIGURE
Reference input voltage vs Free-air temperature	5
Reference input current vs Free-air temperature	6
Cathode current vs Cathode voltage	7, 8
Off-state cathode current vs Free-air temperature	9
Ratio of delta reference voltage to change in cathode voltage vs Free-air temperature	10
Equivalent input noise voltage vs Frequency	11
Equivalent input noise voltage over a 10-second period	12
Small-signal voltage amplification vs Frequency	13
Reference impedance vs Frequency	14
Pulse response	15
Stability boundary conditions	16

Table 2. Application Circuits

	FIGURE
Shunt regulator	17
Single-supply comparator with temperature-compensated threshold	18
Precision high-current series regulator	19
Output control of a 3-terminal fixed regulator	20
High-current shunt regulator	21
Crowbar circuit	22
Precision 5-V 1.5-A regulator	23
Efficient 5-V precision regulator	24
PWM converter with reference	25
Voltage monitor	26
Delay timer	27
Precision current limiter	28
Precision constant-current sink	29

TYPICAL CHARACTERISTICS

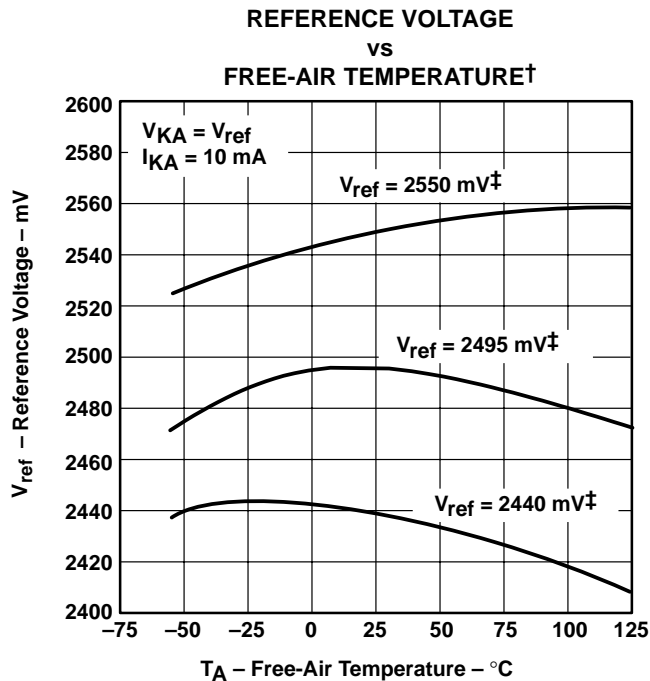

† Data is applicable only within the recommended operating free-air temperature ranges of the various devices.

‡ Data is for devices having the indicated value of  $V_{ref}$  at  $I_{KA} = 10\text{ mA}$ ,  $T_A = 25^\circ\text{C}$ .

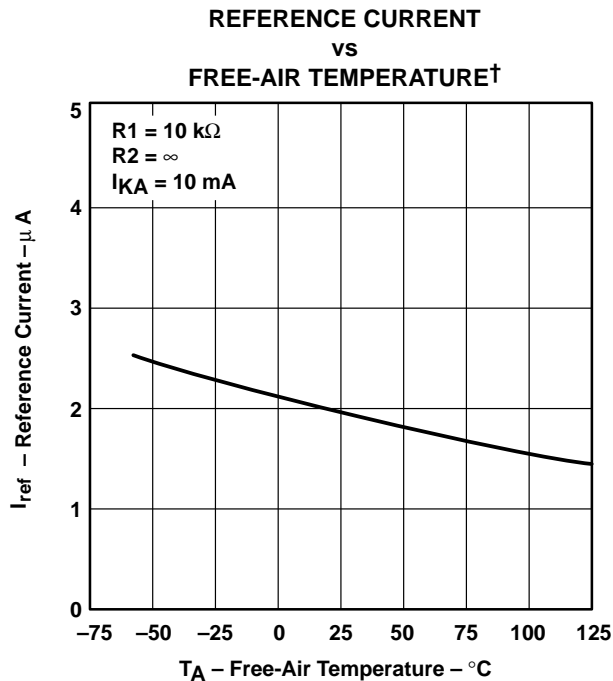

† Data is applicable only within the recommended operating free-air temperature ranges of the various devices.

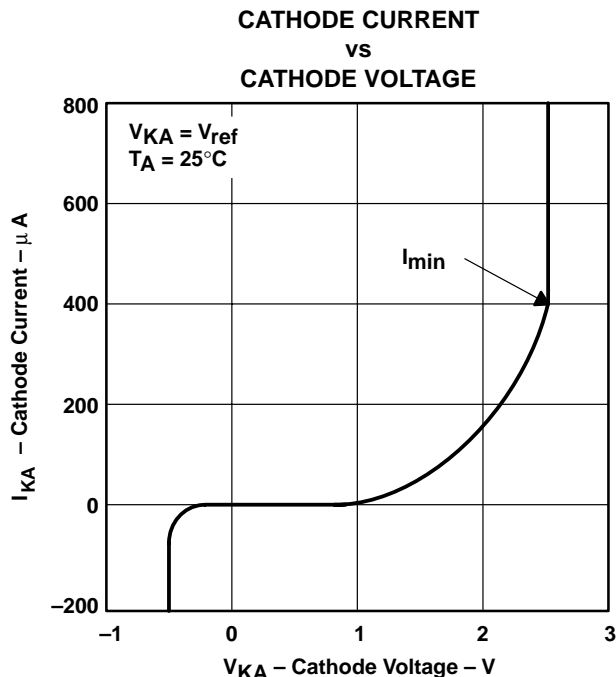
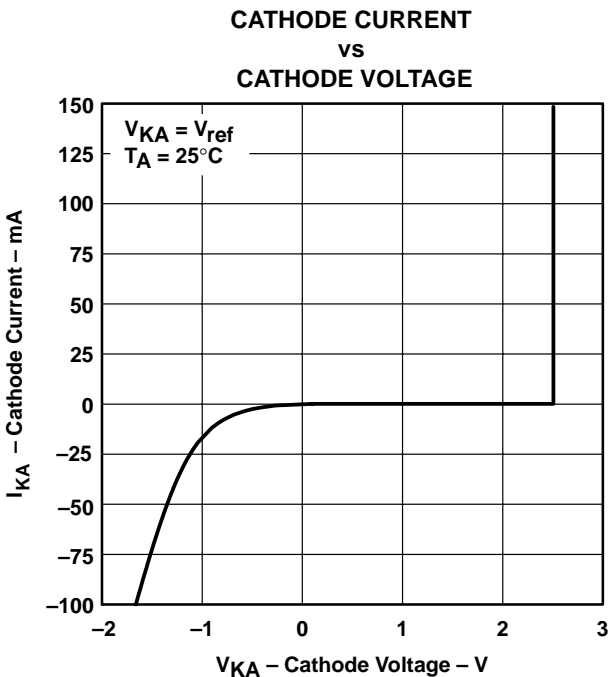

# TL431C, TL431AC, TL431I, TL431AI, TL431M, TL431Y ADJUSTABLE PRECISION SHUNT REGULATORS

SLVS005I – JULY 1978 – REVISED AUGUST 1998

## TYPICAL CHARACTERISTICS

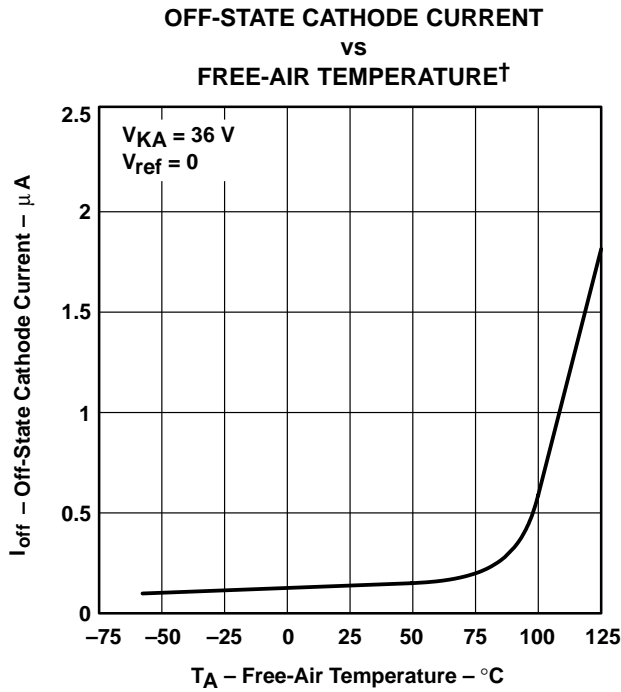

† Data is applicable only within the recommended operating free-air temperature ranges of the various devices.

Figure 9

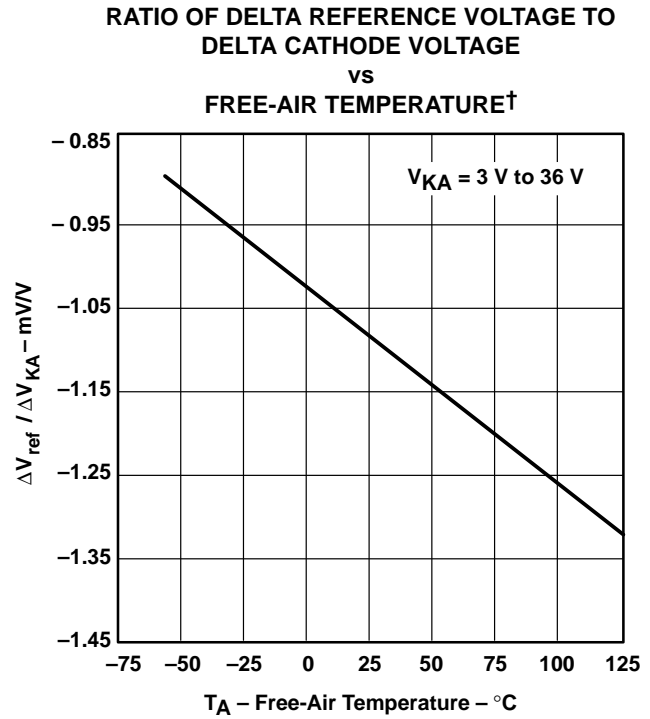

† Data is applicable only within the recommended operating free-air temperature ranges of the various devices.

Figure 10

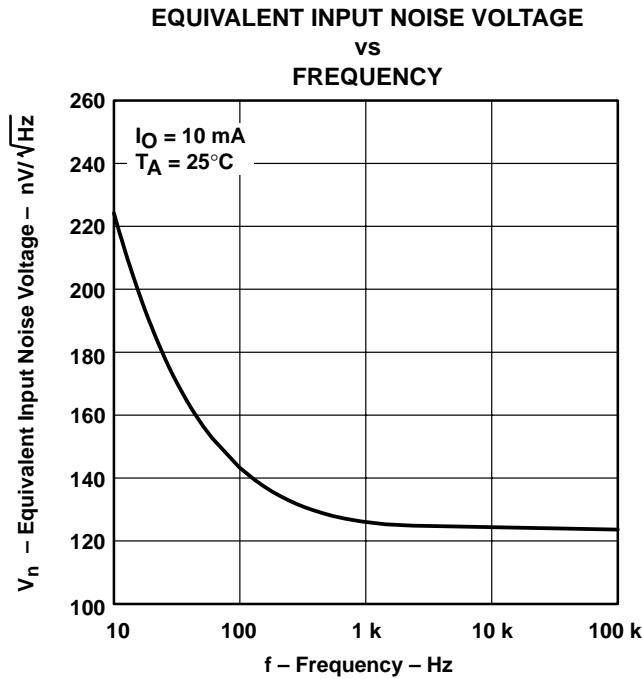

Figure 11



TYPICAL CHARACTERISTICS

EQUIVALENT INPUT NOISE VOLTAGE  
 OVER A 10-SECOND PERIOD

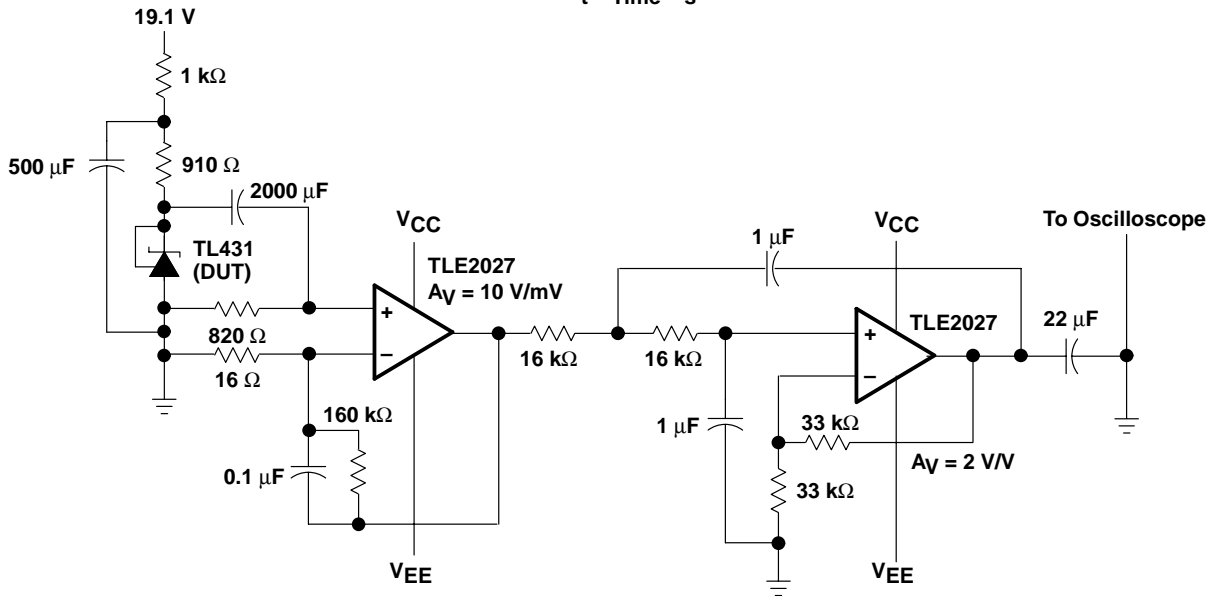
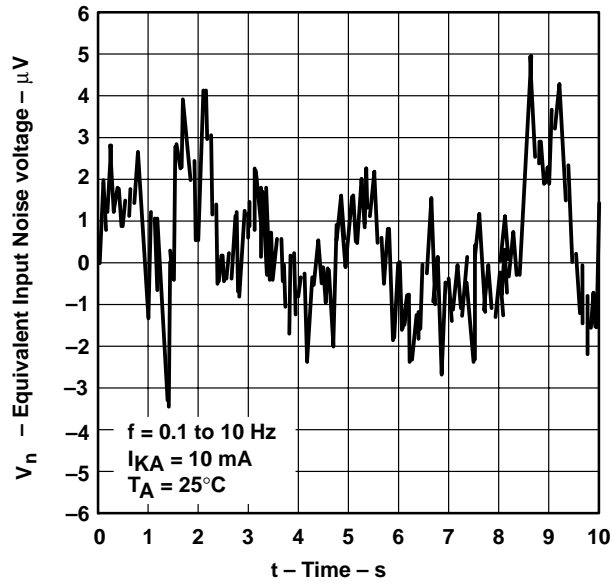

Figure 12. Test Circuit for Equivalent Input Noise Voltage

# TL431C, TL431AC, TL431I, TL431AI, TL431M, TL431Y ADJUSTABLE PRECISION SHUNT REGULATORS

SLVS005I – JULY 1978 – REVISED AUGUST 1998

## TYPICAL CHARACTERISTICS

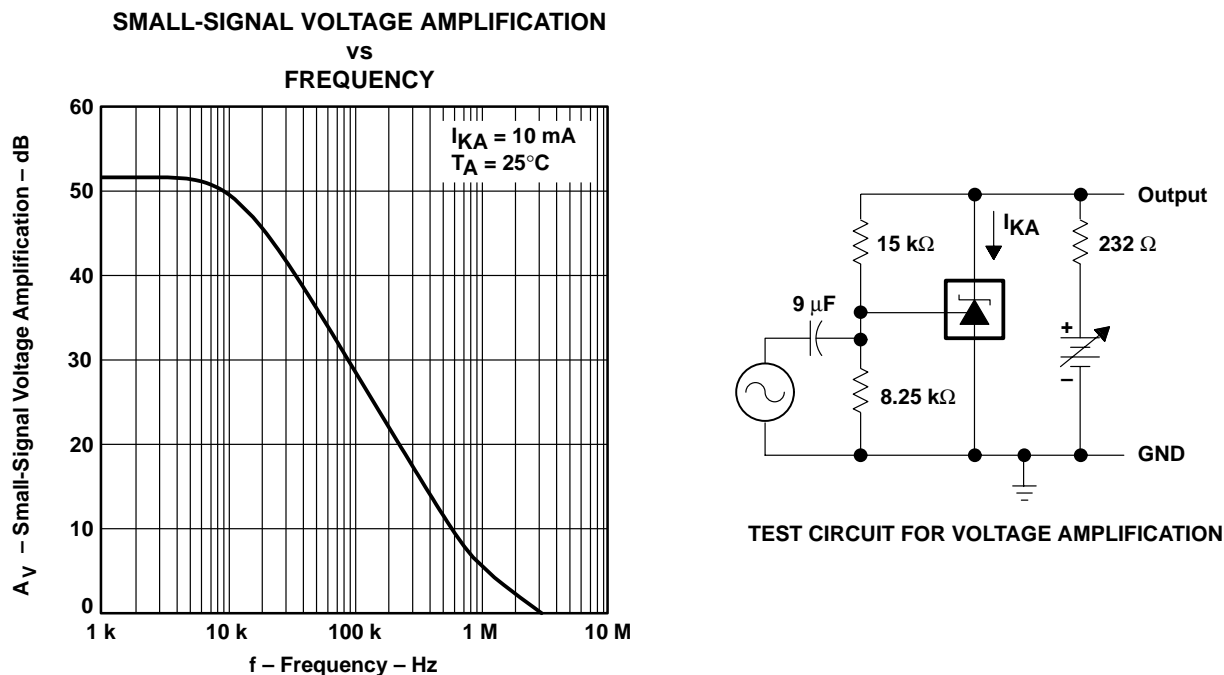

Figure 13

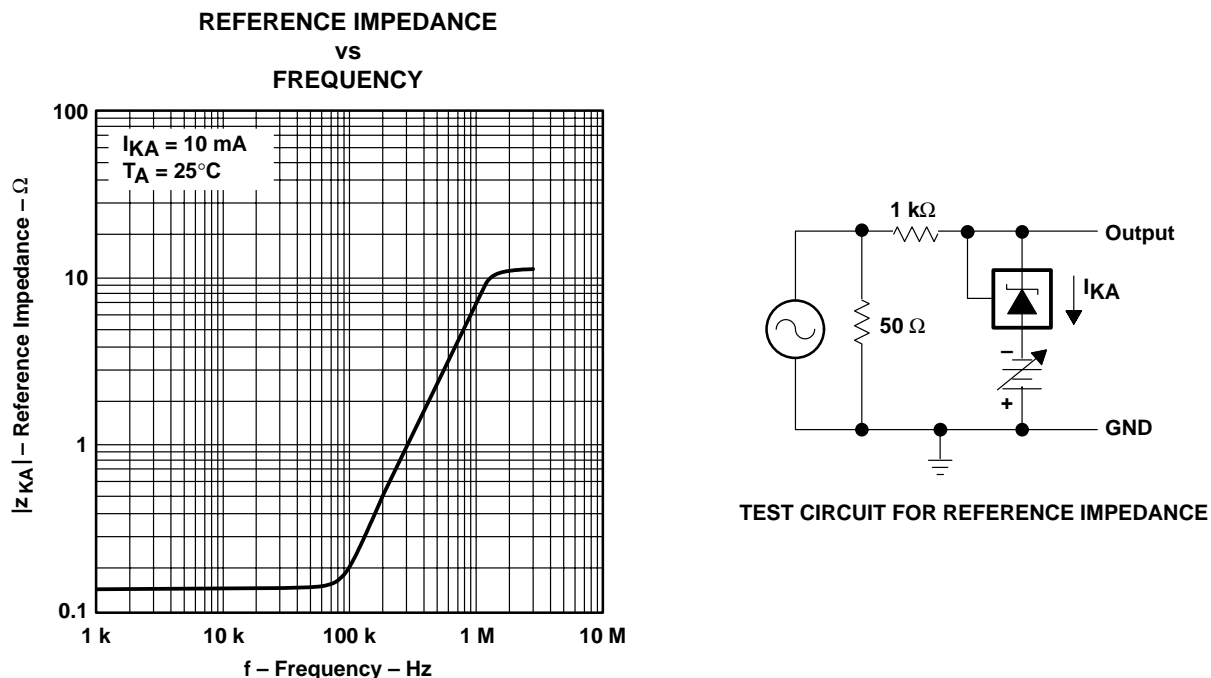

Figure 14

TYPICAL CHARACTERISTICS

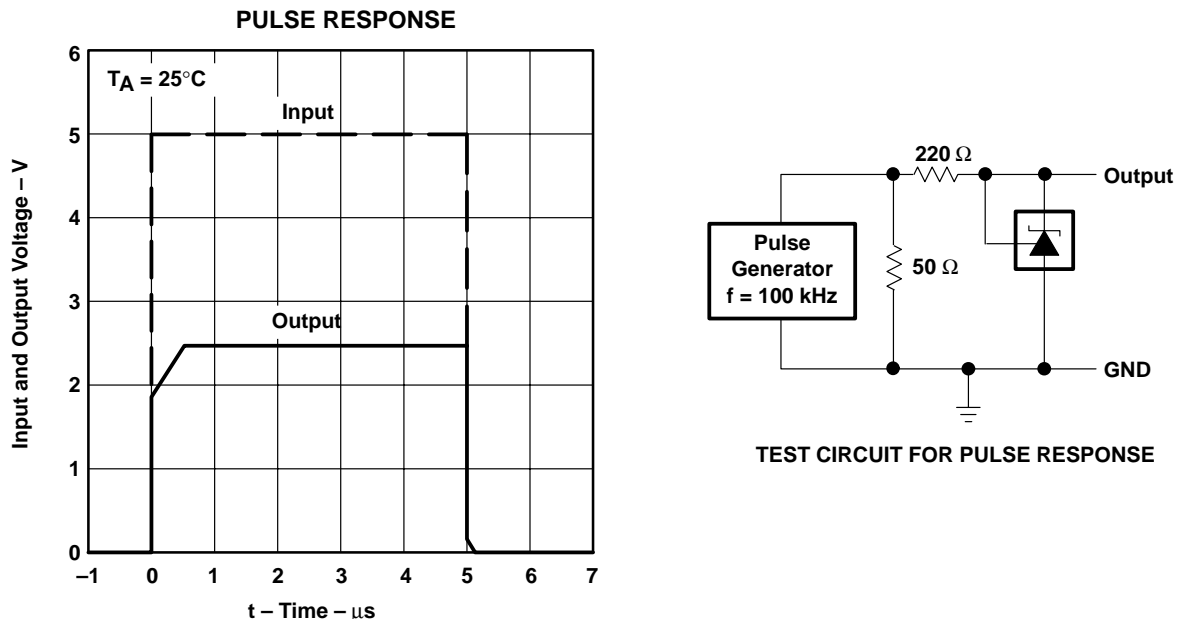

Figure 15

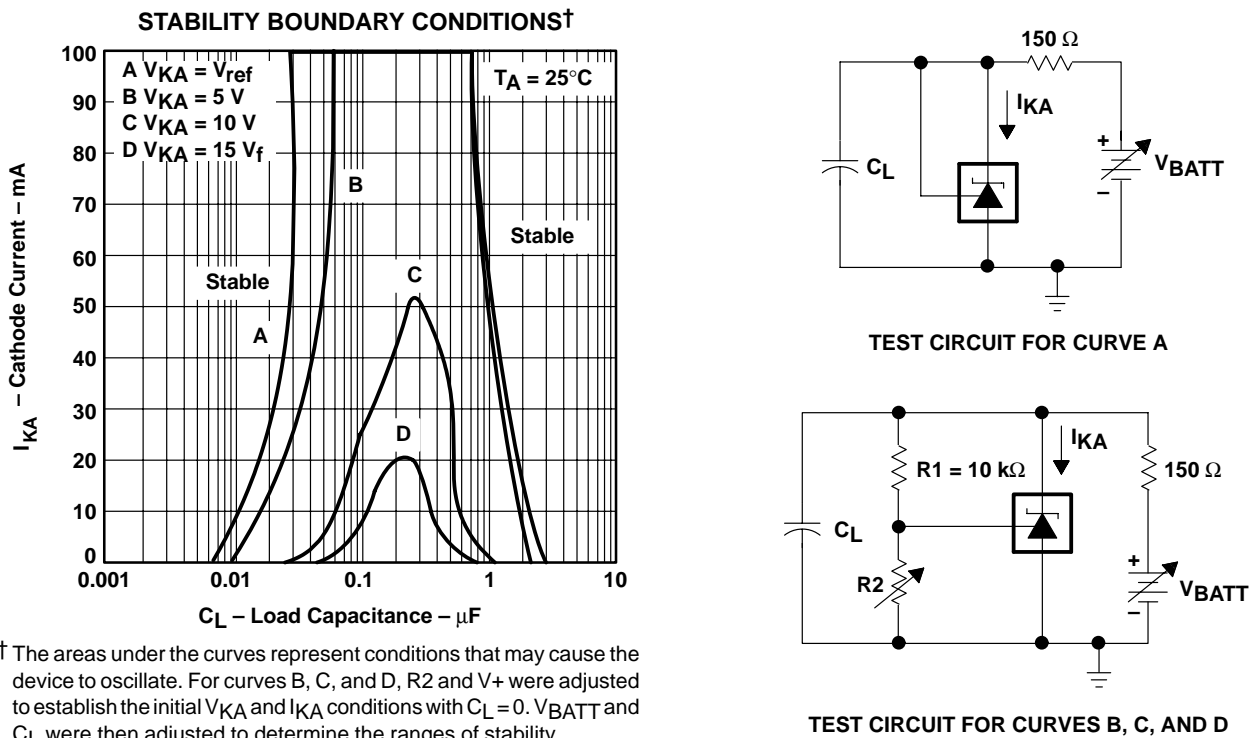
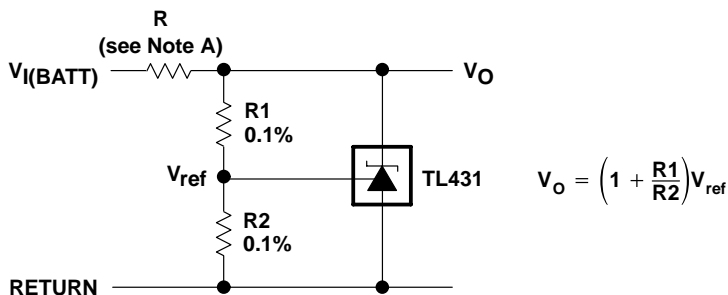

Figure 16

# TL431C, TL431AC, TL431I, TL431AI, TL431M, TL431Y ADJUSTABLE PRECISION SHUNT REGULATORS

SLVS005I – JULY 1978 – REVISED AUGUST 1998

## APPLICATION INFORMATION



NOTE A: R should provide cathode current  $\geq 1$  mA to the TL431 at minimum  $V_{I(BATT)}$ .

Figure 17. Shunt Regulator

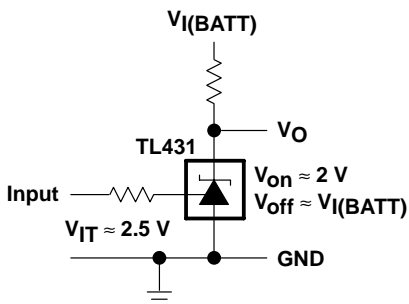
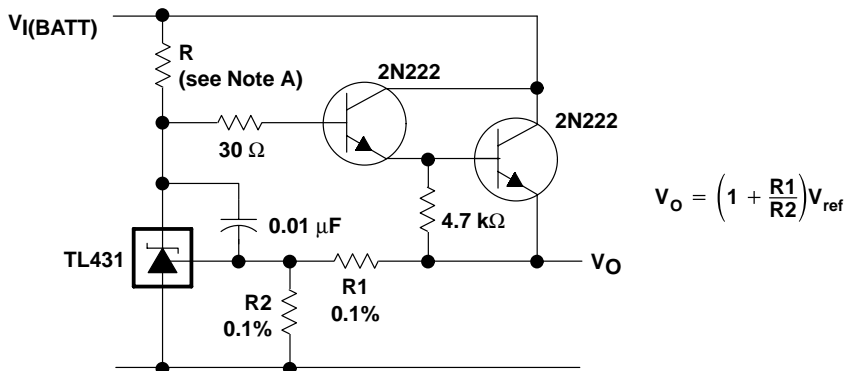

Figure 18. Single-Supply Comparator With Temperature-Compensated Threshold



NOTE A: R should provide cathode current  $\geq 1$  mA to the TL431 at minimum  $V_{I(BATT)}$ .

Figure 19. Precision High-Current Series Regulator



APPLICATION INFORMATION

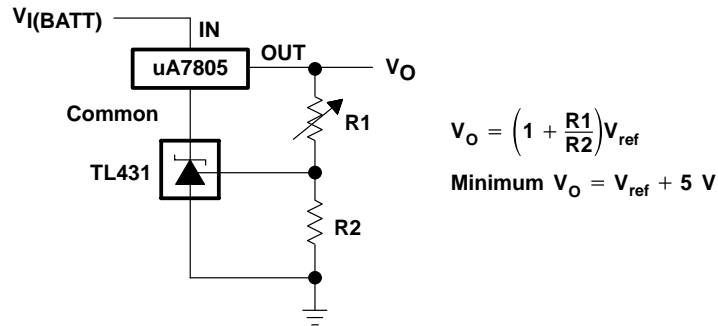

Figure 20. Output Control of a 3-Terminal Fixed Regulator

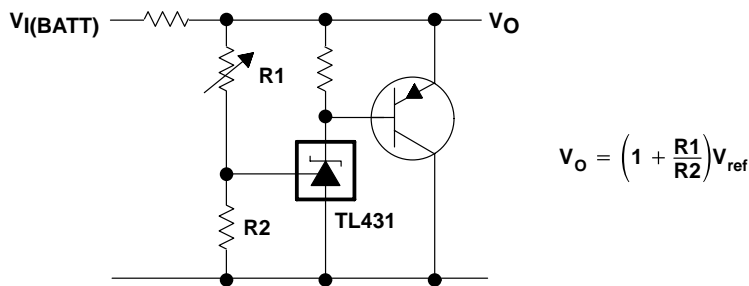
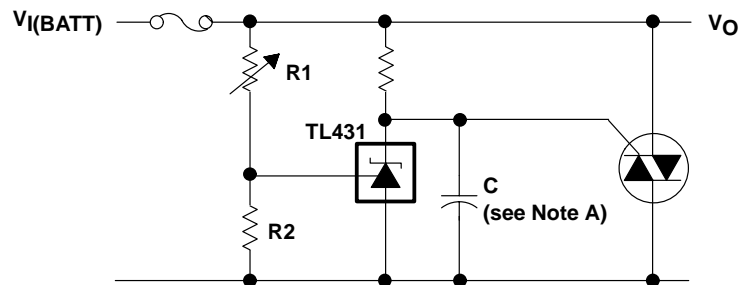

Figure 21. High-Current Shunt Regulator



NOTE A: Refer to the stability boundary conditions in Figure 16 to determine allowable values for C.

Figure 22. Crowbar Circuit

# TL431C, TL431AC, TL431I, TL431AI, TL431M, TL431Y ADJUSTABLE PRECISION SHUNT REGULATORS

SLVS005I – JULY 1978 – REVISED AUGUST 1998

## APPLICATION INFORMATION

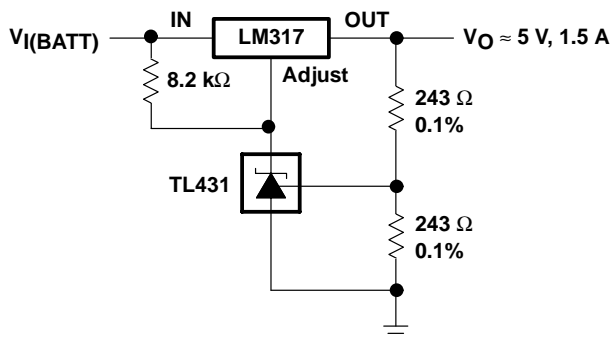
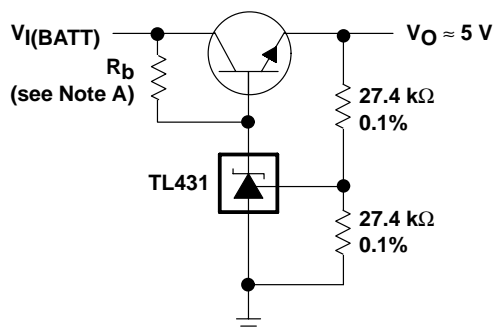

Figure 23. Precision 5-V 1.5-A Regulator



NOTE A:  $R_b$  should provide cathode current  $\geq 1$ -mA to the TL431.

Figure 24. Efficient 5-V Precision Regulator

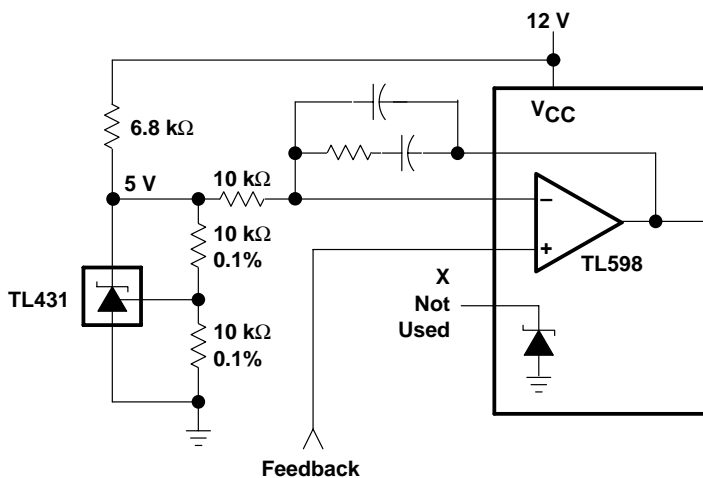
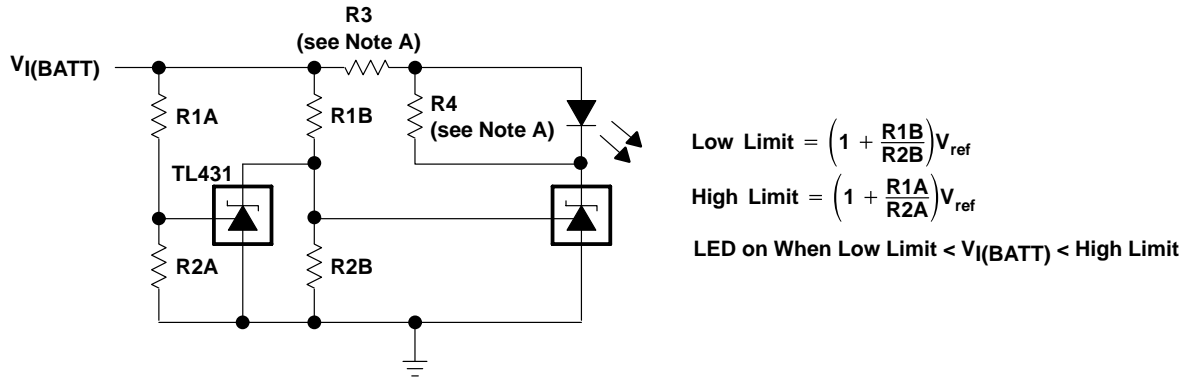

Figure 25. PWM Converter With Reference

APPLICATION INFORMATION



NOTE A: R3 and R4 are selected to provide the desired LED intensity and cathode current  $\geq 1$  mA to the TL431 at the available  $V_I(BATT)$ .

Figure 26. Voltage Monitor

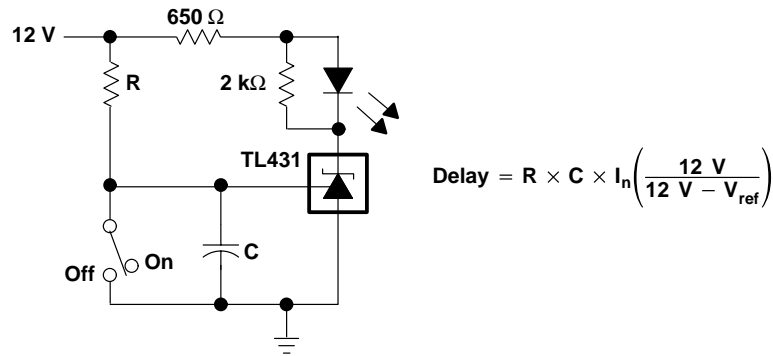

Figure 27. Delay Timer

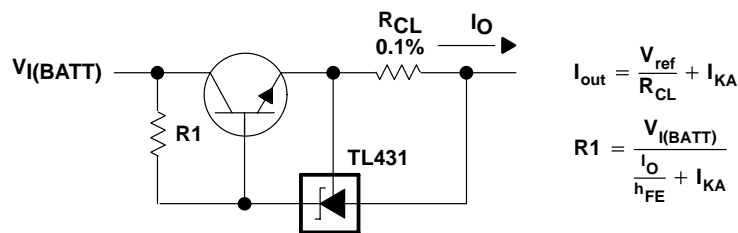

Figure 28. Precision Current Limiter

# TL431C, TL431AC, TL431I, TL431AI, TL431M, TL431Y ADJUSTABLE PRECISION SHUNT REGULATORS

SLVS005I – JULY 1978 – REVISED AUGUST 1998

---

## APPLICATION INFORMATION

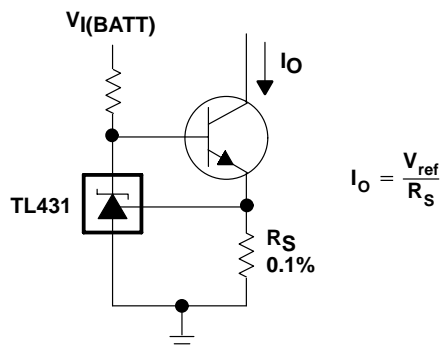

Figure 29. Precision Constant-Current Sink

## **IMPORTANT NOTICE**

Texas Instruments and its subsidiaries (TI) reserve the right to make changes to their products or to discontinue any product or service without notice, and advise customers to obtain the latest version of relevant information to verify, before placing orders, that information being relied on is current and complete. All products are sold subject to the terms and conditions of sale supplied at the time of order acknowledgement, including those pertaining to warranty, patent infringement, and limitation of liability.

TI warrants performance of its semiconductor products to the specifications applicable at the time of sale in accordance with TI's standard warranty. Testing and other quality control techniques are utilized to the extent TI deems necessary to support this warranty. Specific testing of all parameters of each device is not necessarily performed, except those mandated by government requirements.

**CERTAIN APPLICATIONS USING SEMICONDUCTOR PRODUCTS MAY INVOLVE POTENTIAL RISKS OF DEATH, PERSONAL INJURY, OR SEVERE PROPERTY OR ENVIRONMENTAL DAMAGE ("CRITICAL APPLICATIONS"). TI SEMICONDUCTOR PRODUCTS ARE NOT DESIGNED, AUTHORIZED, OR WARRANTED TO BE SUITABLE FOR USE IN LIFE-SUPPORT DEVICES OR SYSTEMS OR OTHER CRITICAL APPLICATIONS. INCLUSION OF TI PRODUCTS IN SUCH APPLICATIONS IS UNDERSTOOD TO BE FULLY AT THE CUSTOMER'S RISK.**

In order to minimize risks associated with the customer's applications, adequate design and operating safeguards must be provided by the customer to minimize inherent or procedural hazards.

TI assumes no liability for applications assistance or customer product design. TI does not warrant or represent that any license, either express or implied, is granted under any patent right, copyright, mask work right, or other intellectual property right of TI covering or relating to any combination, machine, or process in which such semiconductor products or services might be or are used. TI's publication of information regarding any third party's products or services does not constitute TI's approval, warranty or endorsement thereof.